

Operating instruction
Inline Deflagration Flame Arrester 1013-0004
(Suitable for endurance burning)

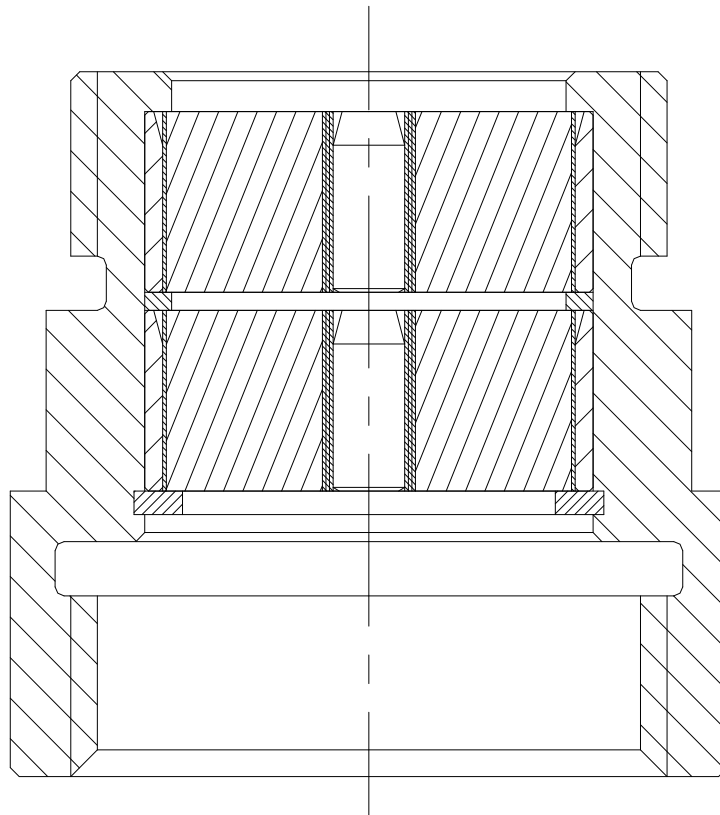

IBExU 10 ATEX 2071 X

 G IIA1 (I)



1. Preface

These operating instructions apply to inline deflagration flame arrester 1013–0004 provided the fact that your inline deflagration flame arrester meet all technical standards described in this document.

Any information required for the assembly, use and maintenance of the protective system may be obtained from these instructions.

Please read the operating instructions on hand carefully to ensure the safe use of this deflagrations flame arrester.

All assembly and maintenance work needs to be carried out by qualified staff.

Information provided in this document may be subject to change without prior notice. This document or individual parts of it may not be multiplied or copied without the written consent of Flammer GmbH, irrespective of its purpose.

© 2012 by Flammer GmbH. All rights reserved.

The trade and/or used name designations, trademarks, etc., even when not specially marked, do not justify the assumption that they may be considered as fair use, as defined by trademark protection laws.

These operating instructions correspond to the current technical state of inline deflagration flame arrester 1013-0004. Changes and errors excepted.

In case of dispute, the German text shall prevail.

2. Symbols



Take note of the accompanying documents!
Important instructions for safe usage

3. Safety regulations and safety instruction

3.1 Safety regulations

The following regulations and guidelines are to be observed for the use of this protective system:

- EC type examination number **IBExU 10 ATEX 2071 X**
- EN ISO 16852 (Replaces EN 12874) Flame arresters
- European Directive 94/9/EC
- National safety regulations
- National workers' protection regulations

3.2 Safety instructions

The following instructions are to be observed to guarantee workers protection and occupational safety:

- Safety regulations in compliance with section 3.1
- Observation of laws and provisions in force at the place of application.
Operators and supervising staff are responsible for the fact that these provisions are observed.
- Assembly and maintenance work is to be carried out by qualified staff.

4. Purpose of use

Inline deflagration flame arrester type 1013-0004 prevents light-back at deflagration and endurance burning of potentially explosive vapour-air, and or gas-air mixtures of explosives group IIA1 (I) with a standard gap > 1.14 mm at a maximum, absolute working pressure of $p_{abs} \leq 1.10$ bar in an ignition source preceding pipe with a maximum nominal diameter of $DN = 25$ mm and a corresponding maximum length of $L = 1250$ mm. (50*DN)



Warning!

Flame arresters are limited in mounting and use.

Pay attention to the following hints according to EN ISO 16852

Type	DEF		Deflagration flame arrester
Lu/D	50		Explanation see chapter 4.1
BC	a		Suitable for endurance burning
EX	G IIA1		Explosion group
To	60	[°C]	Maximum operating temperature
po	1.10	[bar]	Maximum absolute operating pressure

4.1 Special conditions for safe usage

- Max. nominal pipe diameter DN between : 25 mm
the possible ignition source and the inline deflagration flame arrester
- Max. pipe length Lu (incl. connecting pieces) between the possible
ignition source and the inline deflagration flame arrester : 50*DN

Example :

*The allowed maximum pipe length is $L = 50 * DN = 1250$ mm for a connected internal pipe diameter of $DN = 25$ mm*

- Pipe branches and valves on the unprotected side shall be installed as close as possible to the in-line deflagration flame arrester.
- Combustible gases and or liquids produced during operation **must pertain to explosives group IIA1 (I) with a standard gap (MESG) > 1.14 mm.**
- Shut off valves before and after the flame arrester has to be fully open during normal operation.
- The nominal pipe diameter on the unprotected side shall be no larger than the flame arrester connection. The nominal pipe diameter on the protected side shall be no less than the pipe diameter on the unprotected side.
- The Inline deflagration flame arrester may only be used, if the materials resist against the mechanical and/or chemical influences under the actual operating conditions, in such a way, that explosion protection is always guaranteed. This applies particularly to the flame arrester elements whose protection against flame transmission may be endangered by corrosion among others.
- The inline deflagration flame arrester is bi-directional, i.e. that it may be connected to either side of the system.
- The inline deflagration flame arrester is tested and authorised **for endurance burning.**



- The safety against endurance burning is ensured at horizontal mounting position. In case of vertical mounting position the unprotected side has to be above.

5. Technical specifications

(See figure 2)

Connecting screw thread : G1" ISO228-1 internal / external
 Wrench size : 36 mm
 Pressure loss : see fig. 1

6. Assembly

(See figure 2)

The inline deflagration flame arrester is to be fully joined to the respective connecting parts.



- Note requirements of chapter 4.
- The internal diameter of the connecting parts may not exceed the maximum permitted nominal pipe size.
- Any connection is to be sufficiently sealed with suitable media resistant sealing and checked for leakage.

7. Maintenance

To keep impedance at a constantly low level, the inline deflagration flame arrester is to be checked for impurities and, if necessary cleaned, in regular intervals.

Petroleum ether is a suitable cleaning agent, although the instructions of the corresponding safety data sheet in accordance with directive 91/155/EC need to be observed.

Disassembly

(See fig.2)

Remove retaining ring (Pos.4) then flame arrester elements (Pos.2) together with the spacer (Pos.3).

Assembly

After cleaning, reassemble in reverse order.



- Take note for the right order of the flame arrester elements (Pos.2) and the spacer (Pos.3)
- Pay attention for the right gap width of the flame arrester element.
The gap width ($\Delta 0.70$) is mentioned on the type label.
- For safety reason it is not permitted to increase the gaps in the flame arrester elements (e.g. to drill).

After a deflagration:

- All parts (inside and outside) has to be examined and if necessary exchanged.
- In any case, replace flame arrester elements (Pos.2).

After endurance burning:

- Inline deflagration flame arrester has to be exchanged by a new one!

8. Spare parts

For ordering spare parts please declare:

- Type of product
- Complete serial number
- Spare part no. (Please refer to **fig. 2** for items)

Pos.	Name	Order no.
2,3,4	Spare set	8001-0013-00

9. Technical Consultations

Flammer GmbH
Strombergstr. 73
D-74389 Cleebronn

Tel. : ++49 / (0) 7135 / 96 04 58
Fax. : ++49 / (0) 7135 / 96 04 59
E-Mail : info@flammergmbh.de
Homepage : www.flammergmbh.com

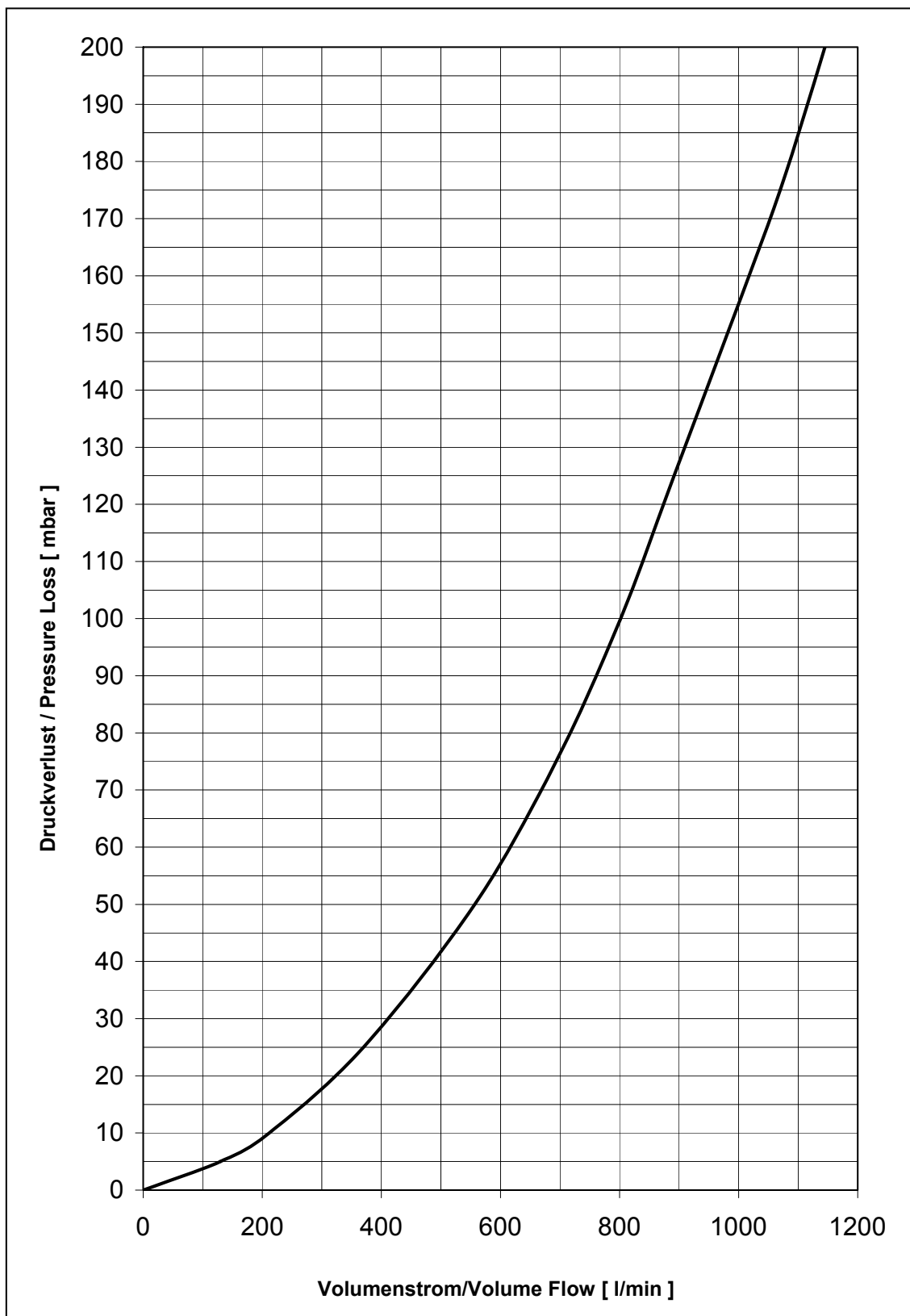
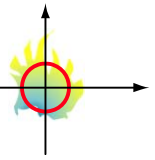
**Fig. 1**

Pressure loss

Medium : Air at $p_0 = 1013 \text{ mbar}$, $T_0 = 273\text{K}$, density = $1,293 \text{ kg/m}^3$

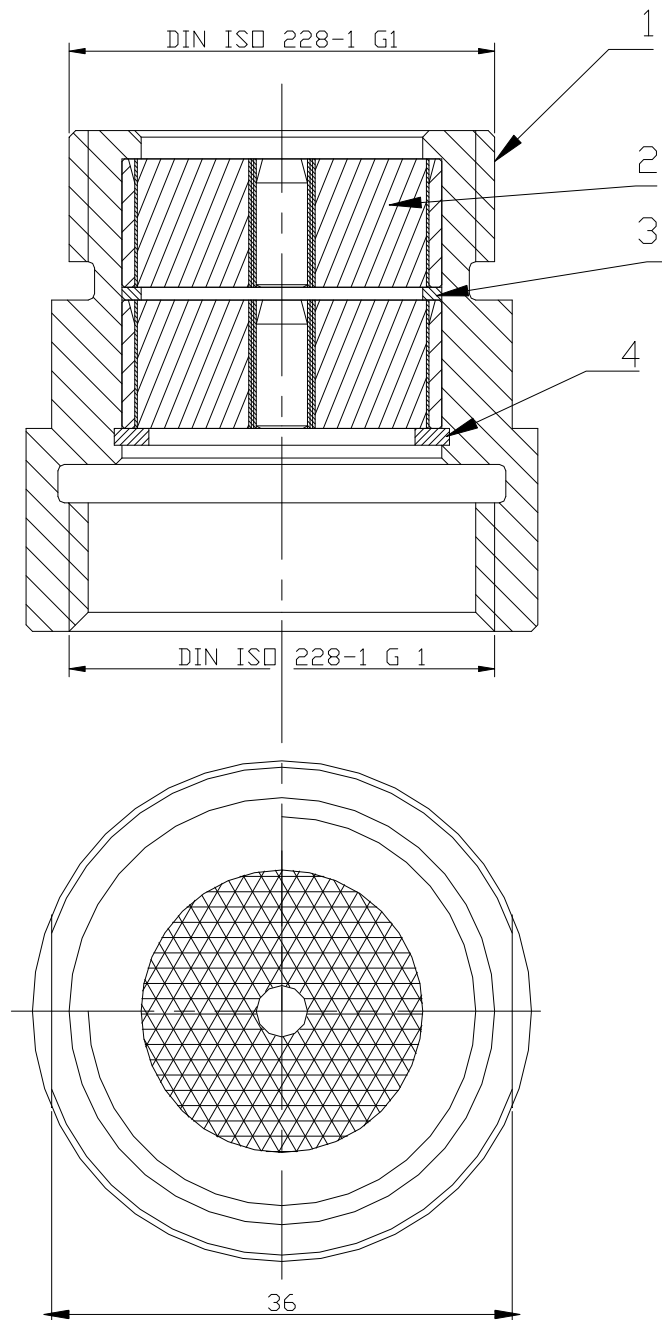

Fig. 2
Construction