



## 1. Preface

These operating instructions apply to inline deflagration flame arrester 1003–0017 provided the fact that your inline deflagration flame arrester meet all technical standards described in this document.

Any information required for the assembly, use and maintenance of the protective system may be obtained from these instructions.

Please read the operating instructions on hand carefully to ensure the safe use of this deflagrations flame arrester.

All assembly and maintenance work needs to be carried out by qualified staff.

Information provided in this document may be subject to change without prior notice.

This document or individual parts of it may not be multiplied or copied without the written consent of Flammer GmbH, irrespective of its purpose.

© 2012 by Flammer GmbH. All rights reserved.

The trade and/or used name designations, trademarks, etc., even when not specially marked, do not justify the assumption that they may be considered as fair use, as defined by trademark protection laws.

These operating instructions correspond to the current technical state of inline deflagration flame arrester 1003-0017. Changes and errors excepted.

In case of dispute, the German text shall prevail.

## 2. Symbols



Take note of the accompanying documents!  
Important instructions for safe usage

## 3. Safety regulations and safety instructions

### 3.1 Safety regulations

The following regulations and guidelines are to be observed for the use of this protective system:

- EC type examination number IBExU 08 ATEX 2123 X
- EN ISO 16852 (Replaces DIN EN12874) Flame arresters
- European Directive 94/9/EC
- National safety regulations
- National workers' protection regulations

### 3.2 Safety instructions

The following instructions are to be observed to guarantee workers protection and occupational safety:

- Safety regulations in compliance with section 3.1
- Observation of laws and provisions in force at the place of application.  
Operators and supervising staff are responsible for the fact that these provisions are observed.
- Assembly and maintenance work is to be carried out by qualified staff.

#### 4. Purpose of use

Inline deflagration flame arrester type 1003-0017 prevents light-back at deflagration of potentially explosive vapour-air, and or gas-air mixtures of explosives group IIA1, IIA or IIB1 with a standard gap  $\geq 0.85$  mm at an absolute working pressure of  $p_{abs} \leq 1.10$  bar in an ignition source preceding pipe with a maximum nominal diameter of  $DN = 25$  mm and a corresponding maximum length of  $L = 1250$  mm. (50\*DN)



#### Warning!

**Flame arresters are limited in mounting and use.**

**Pay attention to the following hints according to EN ISO 16852**

Type	DEF		Deflagration flame arrester
Lu/D	50		Explanation see chapter 4.1
BC	c		Not suitable for endurance burning
EX	G IIB1		Explosion group
To	60	[ °C ]	Maximum operating temperature
po	1.10	[ bar ]	Maximum absolute operating pressure

#### 4.1 Special requirements for safe usage

- Maximum working temperature : 60 °C
- Maximum absolute working pressure  $p_{abs}$  : 1.10 bar
- Max. nominal pipe diameter DN between : 25 mm  
the possible ignition source and the inline deflagration flame arrester
- Max. pipe length L (incl. connecting pieces) between the possible : 1250 mm  
ignition source and the inline deflagration flame arrester
- Max. pipe length L when connected pipe size is **smaller than DN 25** : 50\*DN

##### Example :

*The allowed maximum pipe length is  $L = 50 * DN = 500$  mm for a connected internal pipe diameter of  $DN = 10$  mm*

- Pipe branches and valves on the unprotected side shall be installed as close as possible to the in-line deflagration flame arrester.
- Combustible gases and or liquids produced during operation must pertain to explosives group IIA1, IIA or IIB1 with a standard gap (MESG)  $\geq 0.85$  mm.
- Shut off valves before and after the flame arrester has to be fully open during normal operation.
- The nominal pipe diameter on the unprotected side shall be no larger than the flame arrester connection.  
The nominal pipe diameter on the protected side shall be no less than the pipe diameter on the unprotected side.
- The inline deflagration flame arrester is bi-directional, i.e. that it may be connected to either side of the system.
- The inline deflagration flame arrester may be fitted in any position.
- The end of line - and inline deflagration flame arrester is not tested and authorised for stabilized combustion.
- The inline deflagration flame arrester may only be used, if the materials resist against the mechanical and/or chemical influences under the actual operating conditions, in such a way, that explosion protection is always guaranteed.  
This applies particularly to the flame arrester elements whose protection against flame transmission may be endangered by corrosion among others.

## 5. Technical specifications

(See figure 2)

Connection : Thread G1" ISO228-1 internal  
Pressure loss : see fig. 1

## 6. Assembly

(See figure 2)

The deflagration flame arrester is to be fully joined to the respective connecting parts.



- Note requirements of chapter 4.
- The internal diameter of the connecting parts may not exceed the maximum permitted nominal pipe size.
- Any connection is to be sufficiently sealed with suitable media resistant sealing and checked for leakage. (Maximum test pressure  $p_e = 12$  bar).
- Pay attention to professional earthing!

## 7. Maintenance

To keep flow resistance at a constantly low level, the inline deflagration flame arrester is to be checked for impurities and, if necessary cleaned, in regular intervals.

Petroleum ether could be a suitable cleaning agent, although the instructions of the corresponding safety data sheet in accordance with directive 91/155/EC need to be observed.

### Disassembling

(see fig.2)

Unscrew the bolts (Pos.6, 7) then remove a housing (Pos.1) and the flame arrester element (Pos.2) together with the distance rack (Pos.4).  
If o-ring (Pos.3) is damaged change it.

### Assembly

After cleaning, reassemble in reverse order.

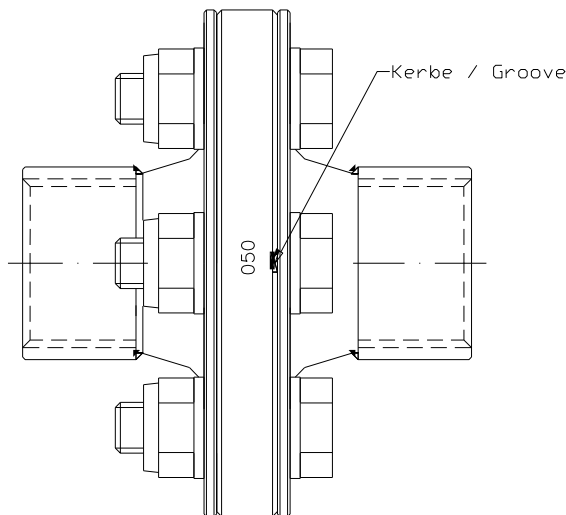

**Tightening moment of bolts Pos.(6, 7):  $40 \pm 2$  Nm**



- Pay attention for the right gap width of the flame arrester element.  
The gap width ( $\Delta 0,50$ ) is mentioned on the type label and the flame arrester element.(see above fig.)
- For safety reason it is not permitted to increase the gaps in the flame arrester elements (e.g. to drill).
- After reassembling check inline deflagration flame arrester for leakage!  
(Maximum test pressure  $p_e = 12$  bar).
- Tighten screws with the required tightening moment after 15 minutes again when using PTFE O-rings.

### **After a deflagration:**

- All parts (inside and outside) has to be examined and if necessary exchanged.
- In any case, replace flame arrester elements (Pos.2).

## 8. Spare parts

For ordering spare parts please declare:

- Type of product
- Complete serial number
- Spare part no. (Please refer to **fig. 2** for items)

Pos.	Name	Order no.
2,3,4	Spare set	8001-0022
4	FKM O-ring	9013-0004-00
4	PTFE O-ring	9013-0005-00

## 9. Technical Consultations

**Flammer GmbH**  
**Daimlerstr. 3**  
**D-74389 Cleebronn**

**Tel.** : ++49 / (0) 7135 / 93 84 21 0  
**Fax.** : ++49 / (0) 7135 / 93 84 21 99  
**E-Mail** : [info@flammergmbh.de](mailto:info@flammergmbh.de)  
**Homepage** : [www.flammergmbh.com](http://www.flammergmbh.com)

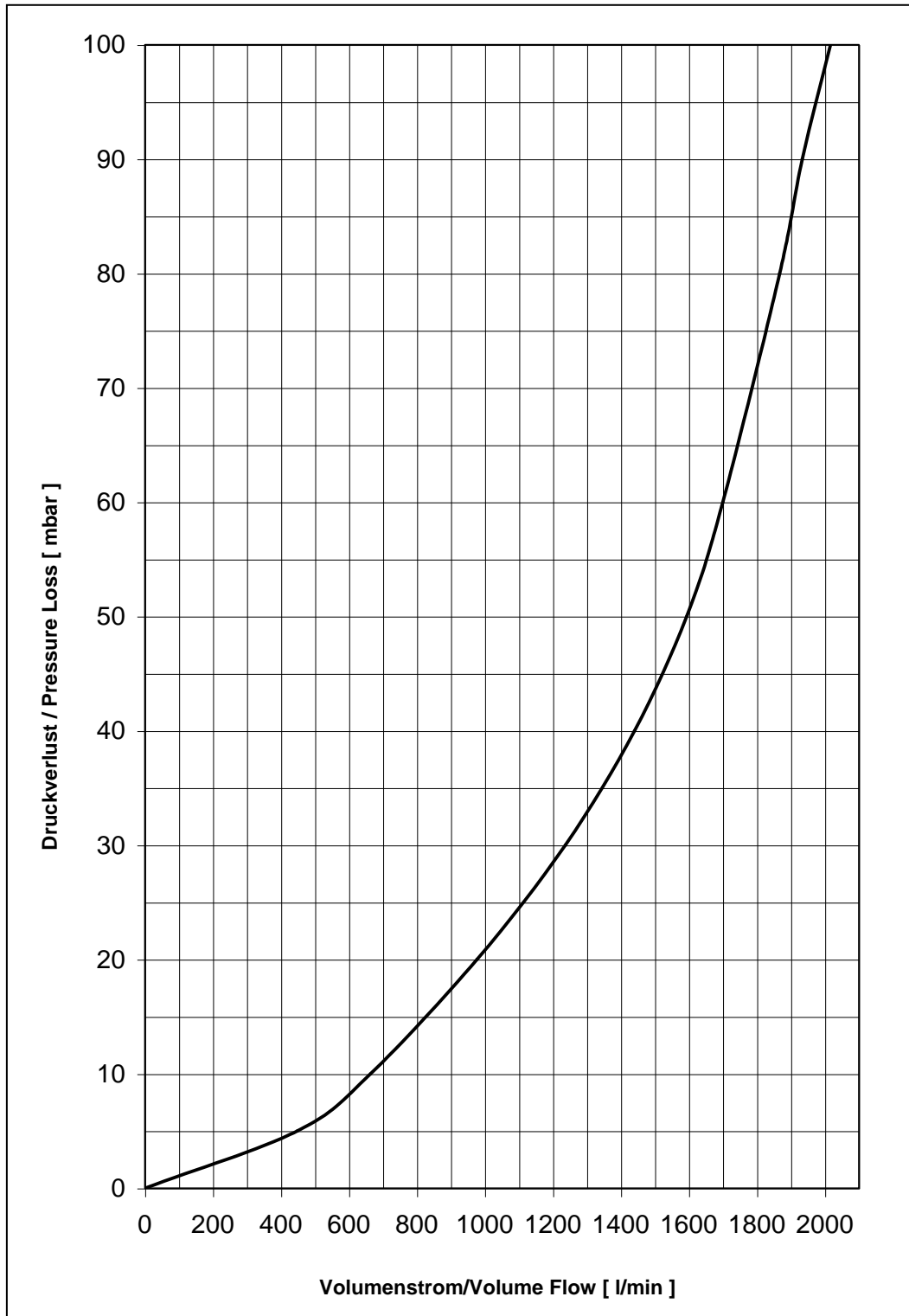

**Fig. 1**  
 Pressure loss  
 Medium : Air at  $p_0 = 1013 \text{ mbar}$ ,  $T_0 = 273\text{K}$ , density =  $1,293 \text{ kg/m}^3$

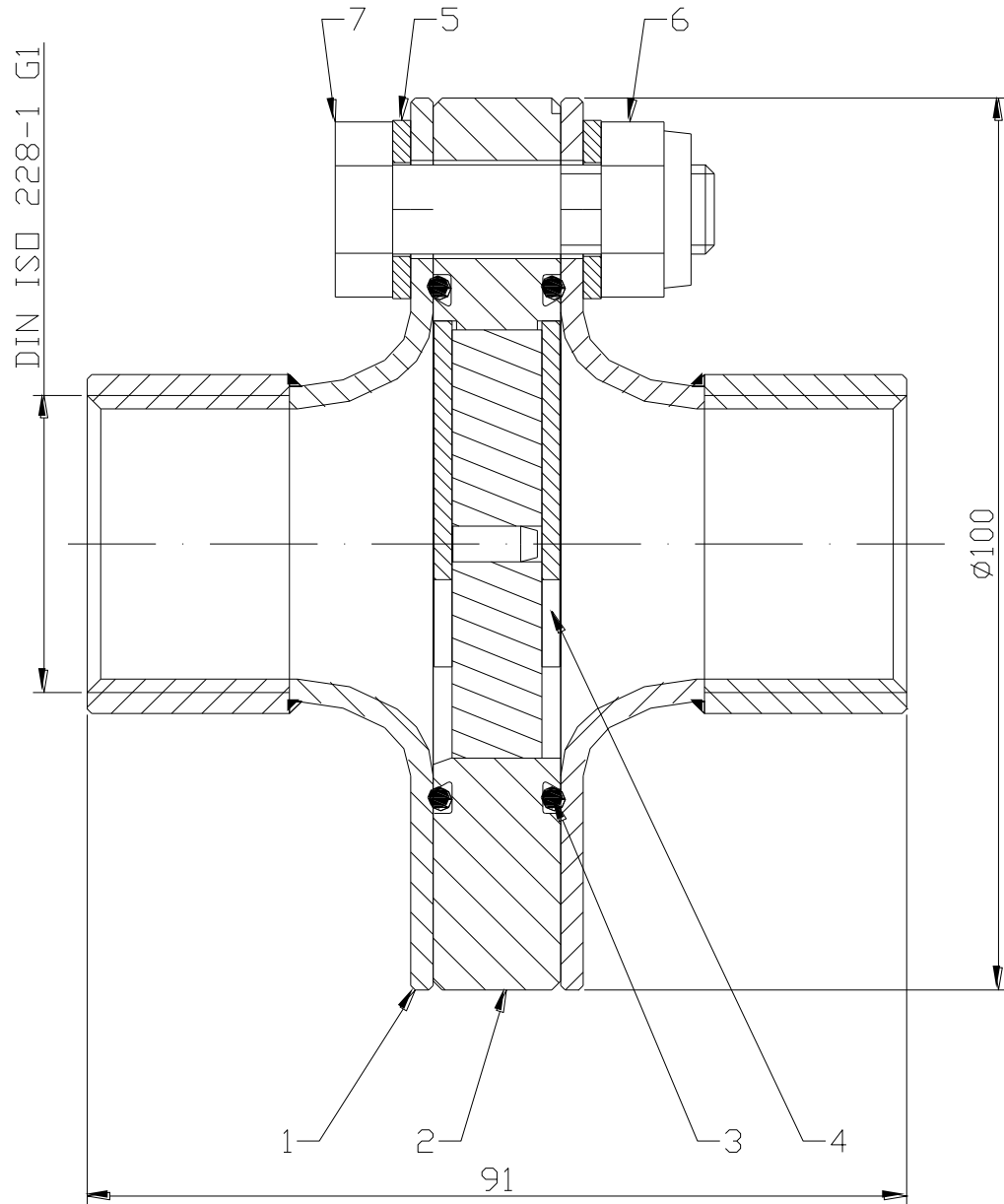

**Fig. 2**  
Construction