

Operating Instruction  
 End of line Deflagration Flame Arrester 1008-0016 to 1008-0024  
 DN25 (1") to DN150 (6")

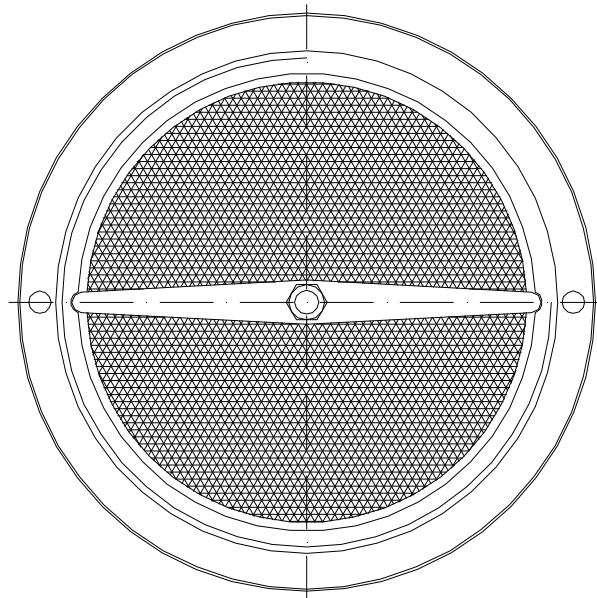

IBExU 15 ATEX 2076 X

 G IIB

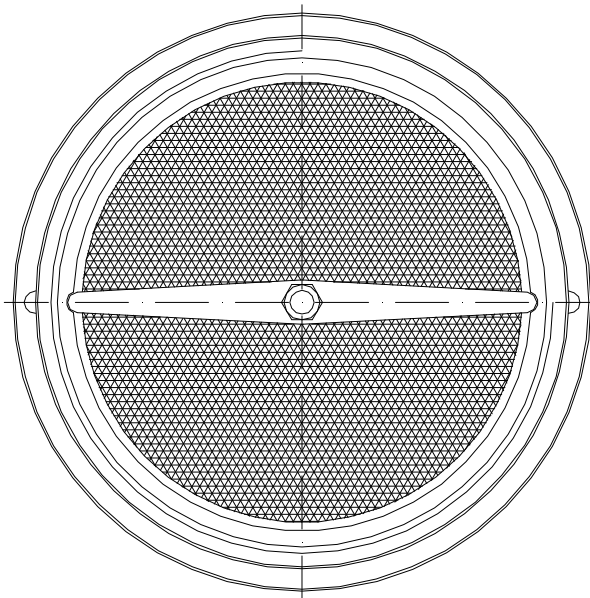
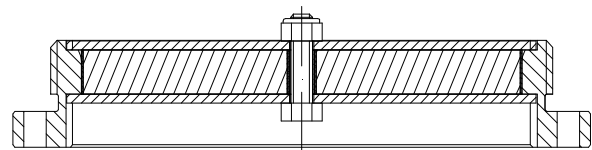
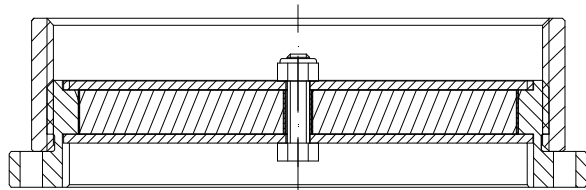

## 1. Preface

This operating instruction apply to end of line deflagration flame arrester type 1008–0016 to 1008-0024, provided the fact that your end of line deflagration flame arrester meets all technical standards described in this document.

The protective system is **not** tested and authorised for endurance burning.

Any information required for the assembly, use and maintenance of the protective system may be obtained from these instructions.

Please read the operating instructions on hand carefully to ensure the safe use of this protective system.

All assembly and maintenance work needs to be carried out by qualified staff.

Information provided in this document may be subject to change without prior notice.

This document or individual parts of it may not be multiplied or copied without the written consent of Flammer GmbH, irrespective of its purpose.

© 2016 by Flammer GmbH. All rights reserved.

The trade and/or used name designations, trademarks, etc., even when not specially marked, do not justify the assumption that they may be considered as fair use, as defined by trademark protection laws. Changes and errors excepted.

In case of dispute, the German text shall prevail.

## 2. Symbols



Take note of the accompanying documents!  
Important instructions for safe usage

## 3. Safety regulations and safety instructions

### 3.1 Safety regulations

The following regulations and guidelines are to be observed for the use of this protective system:

- EC type examination number IBExU 15 ATEX 2076 X
- EN ISO 16852 Flame arresters
- European Directive 2014/34/EU
- National safety regulations
- National workers' protection regulations

### 3.2 Safety instructions

The following instructions are to be observed to guarantee workers protection and occupational safety:

- Safety regulations in compliance with section 3.1
- Observation of laws and provisions in force at the place of application.  
Operators and supervising staff are responsible for the fact that these provisions are observed.
- Assembly and maintenance work is to be carried out by qualified staff.

#### 4. Purpose of use

The end of line deflagration flame arrester type 1008-0016 to 1008-0024 at the end of vent pipes prevents light-back at deflagration of potentially explosive vapour-air, and or gas-air mixtures of explosives group IIA1, IIA, IIB1, IIB2, IIB3 and IIB with a standard gap (MESG)  $\geq 0.50$  mm from outside (atmospheric conditions) to the protected side (e. g. storage tank).



#### Warning!

Flame arresters are limited in mounting and use.

Pay attention to the following hints according to EN ISO 16852

Type	DEF		Deflagration flame arrester
Lu/D	n/a		Not applicable
BC	c		Not suitable for endurance burning
EX	G IIB		Explosion group
To	60	[ °C ]	Maximum operating temperature
po	1.10	[ bar ]	Atmospheric conditions

#### 4.1 Special requirements for safe usage

- The protective system could be fitted in any position.  
Look out for weather protection if necessary to prevent for instance penetrating of rainwater.
- Combustible gases and or liquids produced during operation must pertain to explosives group IIA1, IIA, IIB1, IIB2, IIB3 or IIB with a standard gap (MESG)  $\geq 0.50$  mm.
- The protective system is **not tested and authorised for endurance burning!**
- The protective system may only be used, if the materials resist against the mechanical and/or chemical influences under the actual operating conditions, in such a way, that explosion protection is always guaranteed.  
This applies particularly to the flame arrester elements whose protection against flame transmission may be endangered by corrosion among others.

## 5. Technical specifications (See fig.1)

Connection : Thread in accordance with ISO 228-1  
 Pressure loss : see fig.2 to fig.10

## 6. Assembly (See figure 1)

The end of line deflagration flame arrester is to be fully joined to the respective connecting parts at the open end of the vent pipe.



- Note requirements of chapter 4.
- The internal diameter of the connecting parts may not exceed the maximum permitted nominal pipe size.
- Any connection is to be sufficiently sealed with suitable media resistant sealing and checked for leakage.
- Look out for weather protection if necessary to prevent for instance penetrating of rainwater.

## 7. Maintenance

To keep flow resistance at a constantly low level, the protective system is to be checked for impurities and, if necessary cleaned, in regular intervals.

Petroleum ether is often a applicable cleaning agent, although the instructions of the corresponding safety data sheet in accordance with directive 91/155/EC need to be observed.



### Note!

- For safety reason it is not permitted to increase the gaps in the flame arrester elements (e.g. to drill)!
- Check end of line deflagration flame arrester and connections for leak tightness after assembly!

### After a deflagration:

- All parts has to be examined regarding damage
- If necessary exchange whole end of line deflagration flame arrester.

## 8. Spare parts

Not intended

## 9. Technical Consultations

Flammer GmbH  
 Daimlerstr. 3  
 D-74389 Cleebronn

Tel. : ++49 / (0) 7135 / 93 84 21 0  
 Fax. : ++49 / (0) 7135 / 93 84 21 99  
 E-mail : [info@flammergmbh.de](mailto:info@flammergmbh.de)  
 Homepage : [www.flammergmbh.de](http://www.flammergmbh.de)

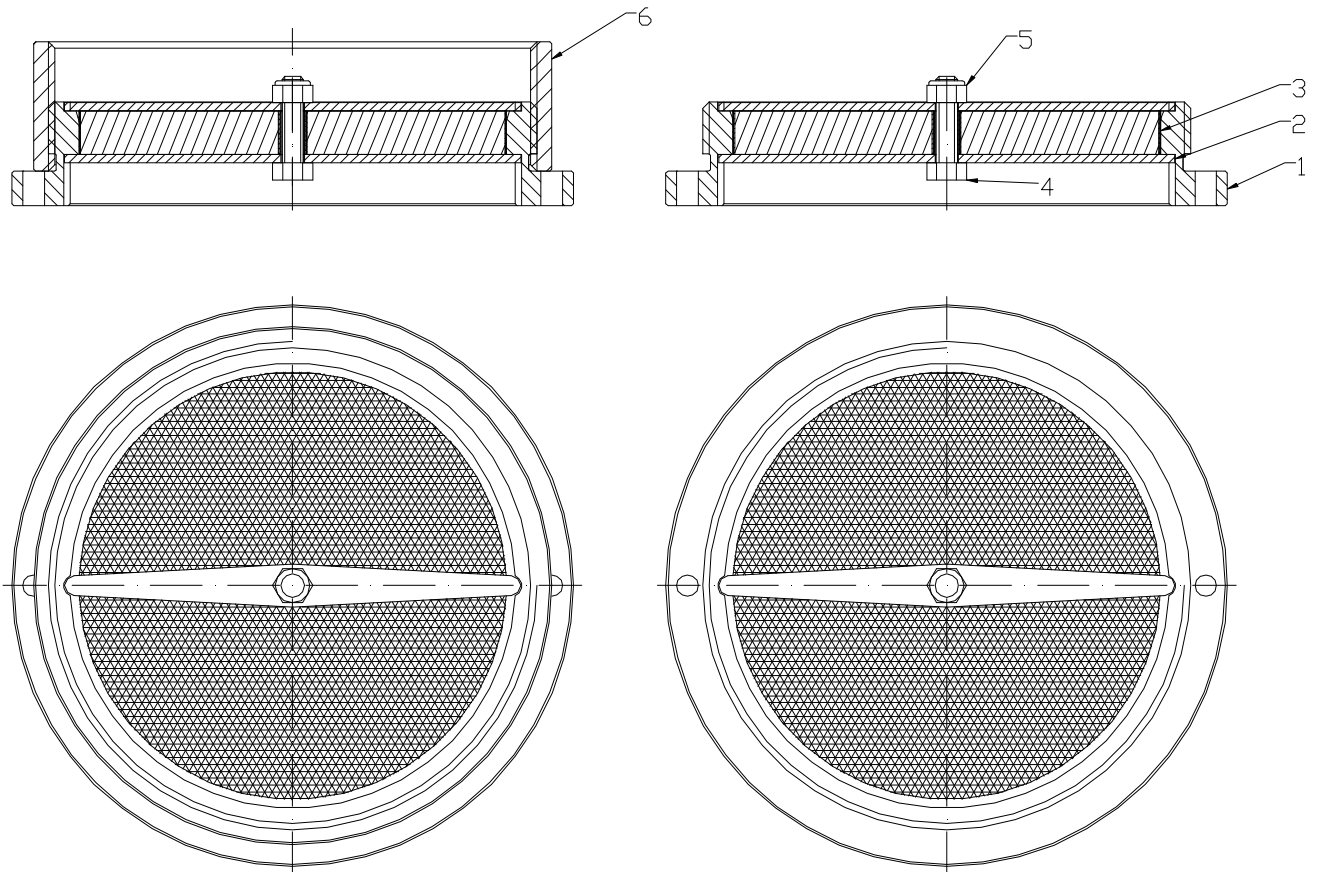

**Fig. 1**  
Construction

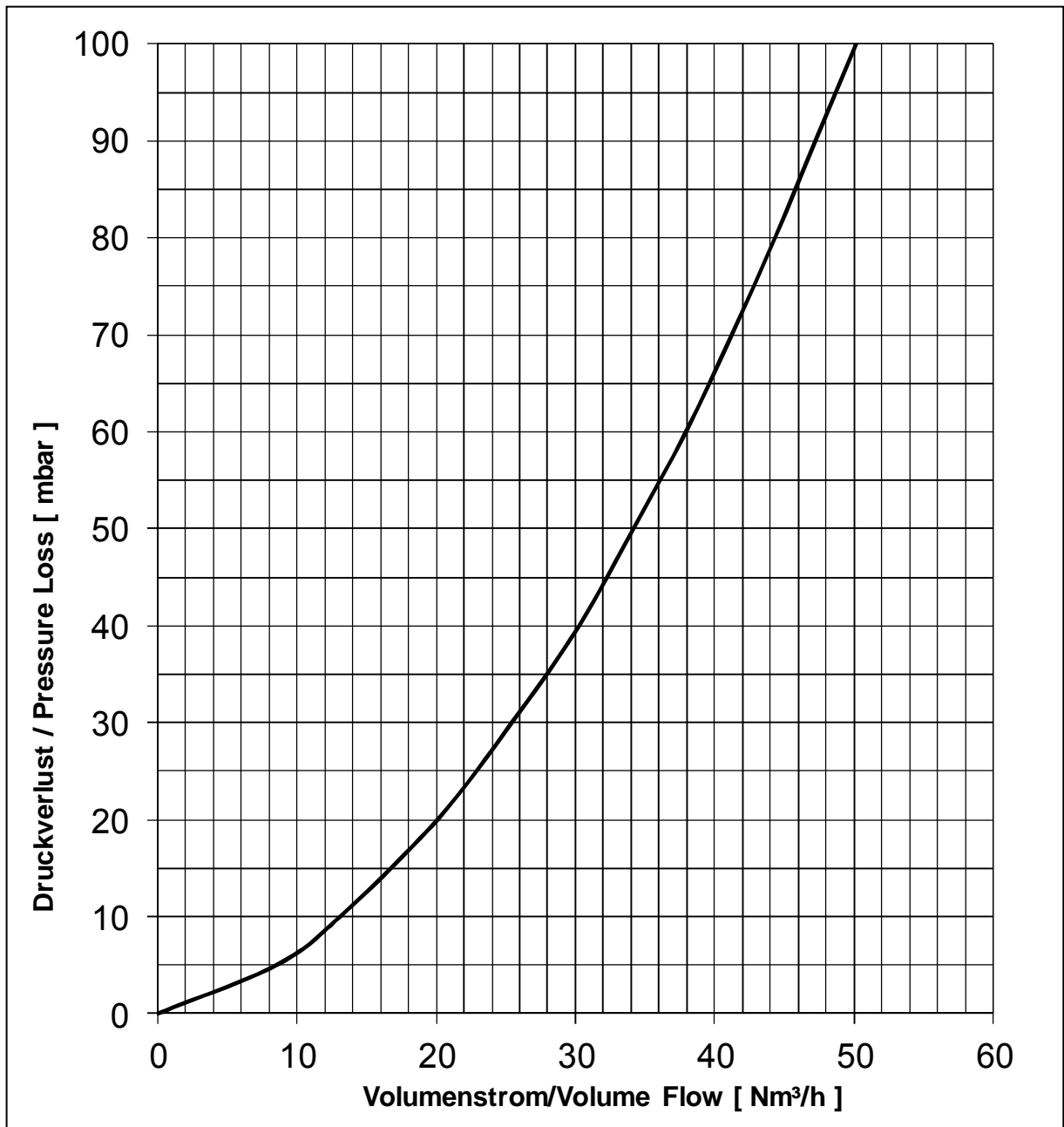

**Fig. 2**

Pressure loss 1008-0016 (DN 1")

Medium : Air at  $p_0 = 1013 \text{ mbar}$ ,  $T_0 = 273\text{K}$ , density =  $1,293 \text{ kg/m}^3$

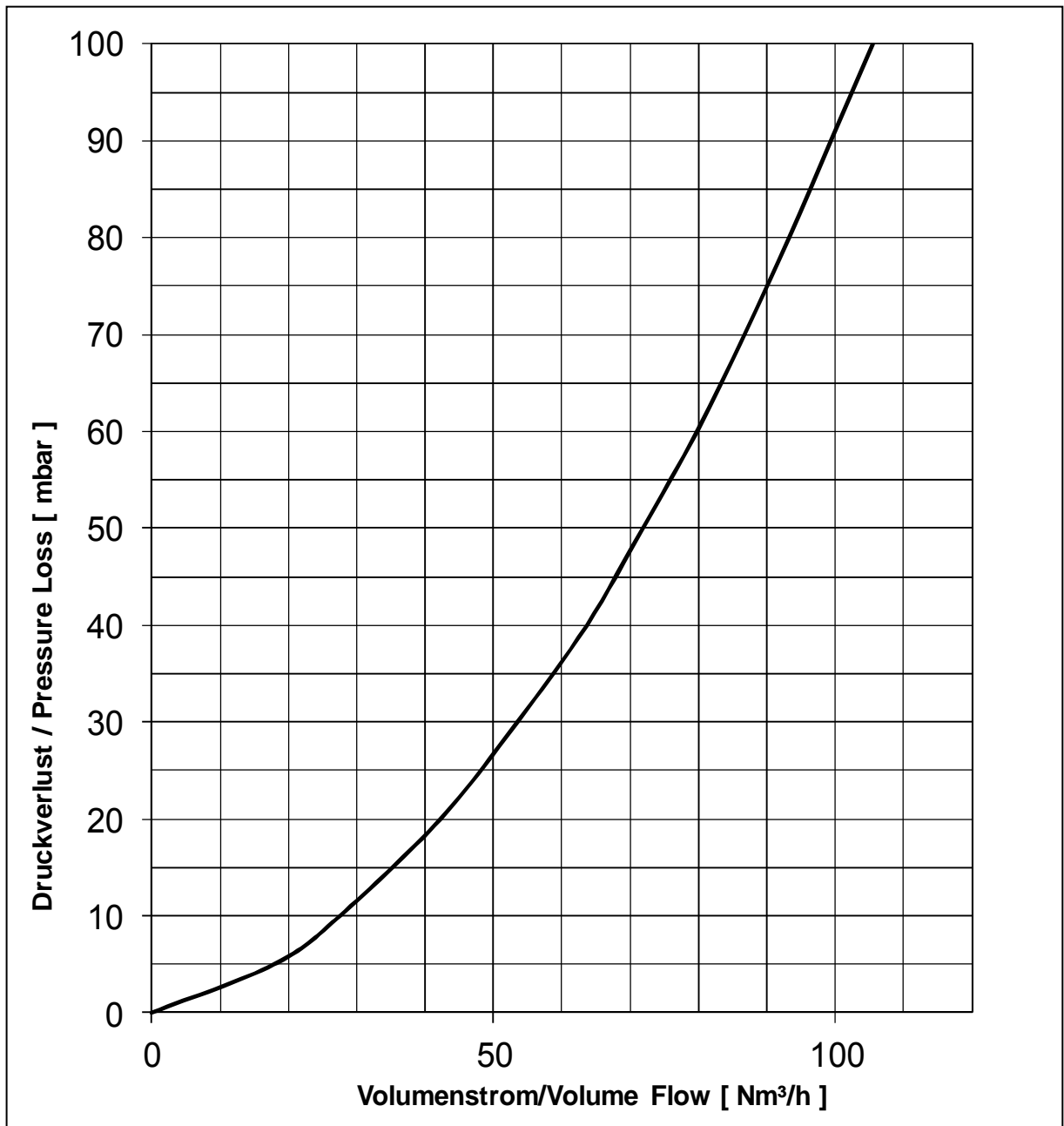

**Fig. 3**

Pressure loss 1008-0017 (DN 1 ¼")

Medium : Air at  $p_0 = 1013 \text{ mbar}$ ,  $T_0 = 273\text{K}$ , density =  $1,293 \text{ kg/m}^3$

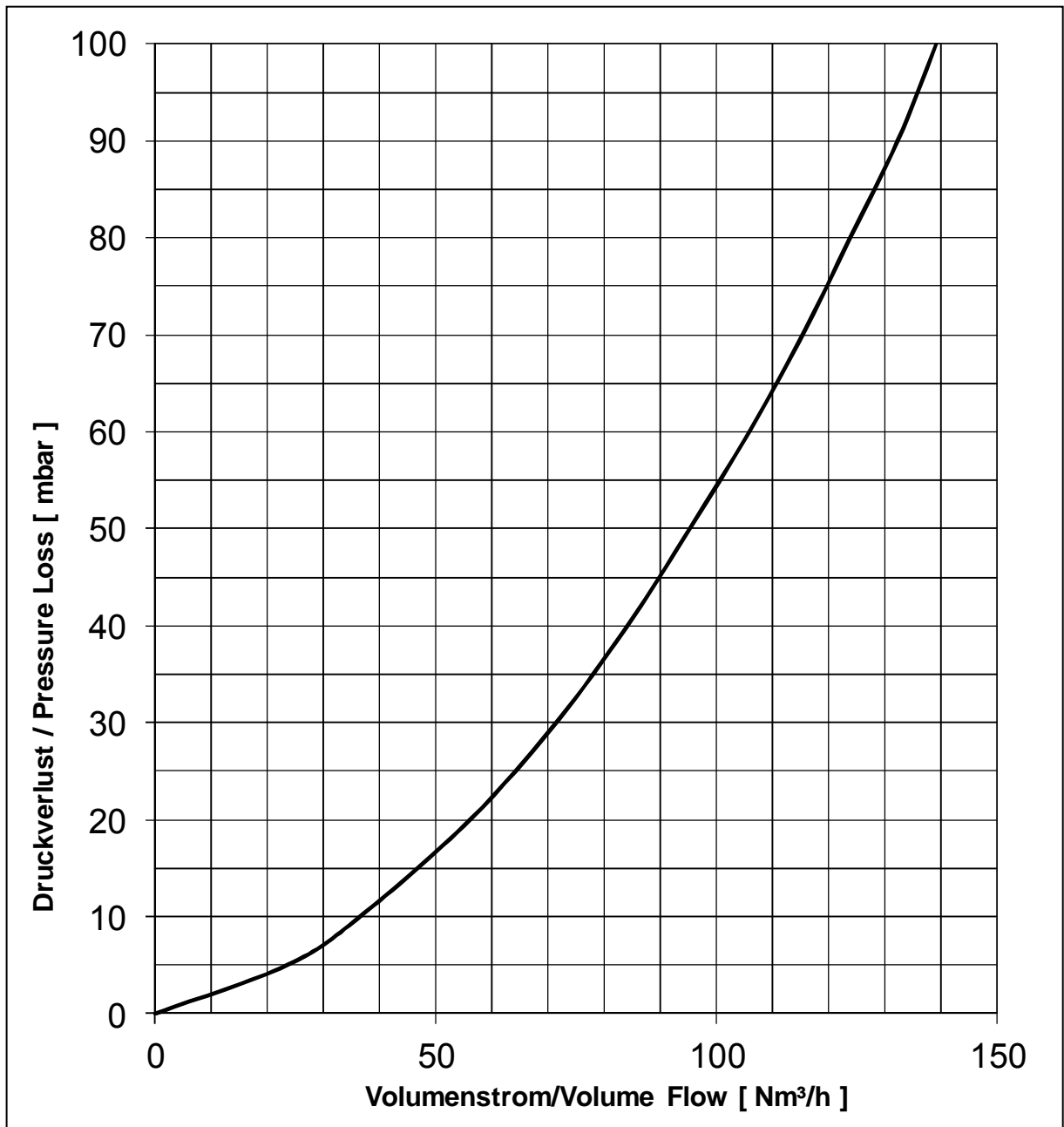

**Fig. 4**

Pressure loss 1008-0018 (DN 1 ½")

Medium : Air at  $p_0 = 1013 \text{ mbar}$ ,  $T_0 = 273\text{K}$ , density =  $1,293 \text{ kg/m}^3$

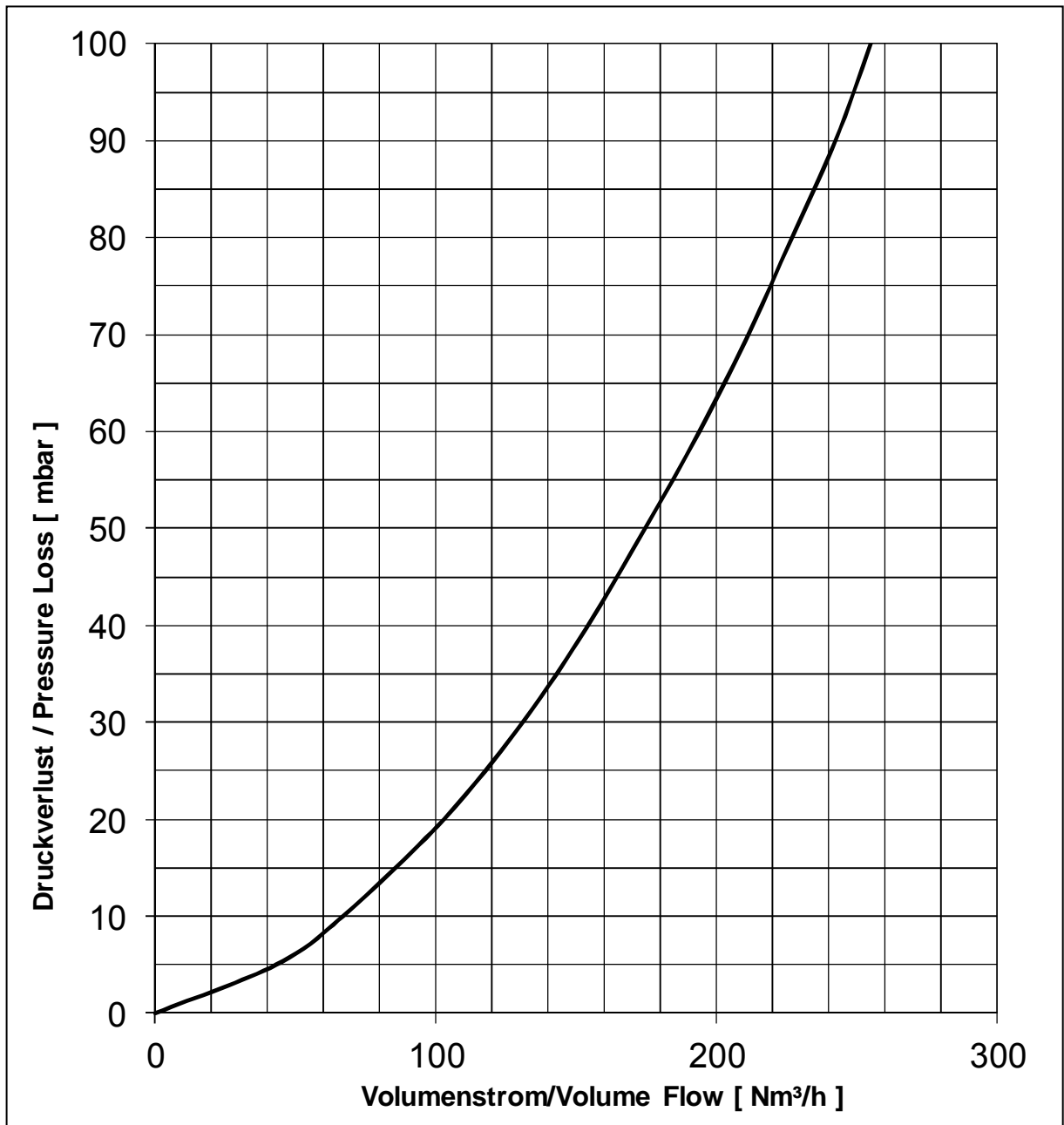

**Fig. 5**

Pressure loss 1008-0019 (DN 2")

Medium : Air at  $p_0 = 1013 \text{ mbar}$ ,  $T_0 = 273\text{K}$ , density =  $1,293 \text{ kg/m}^3$

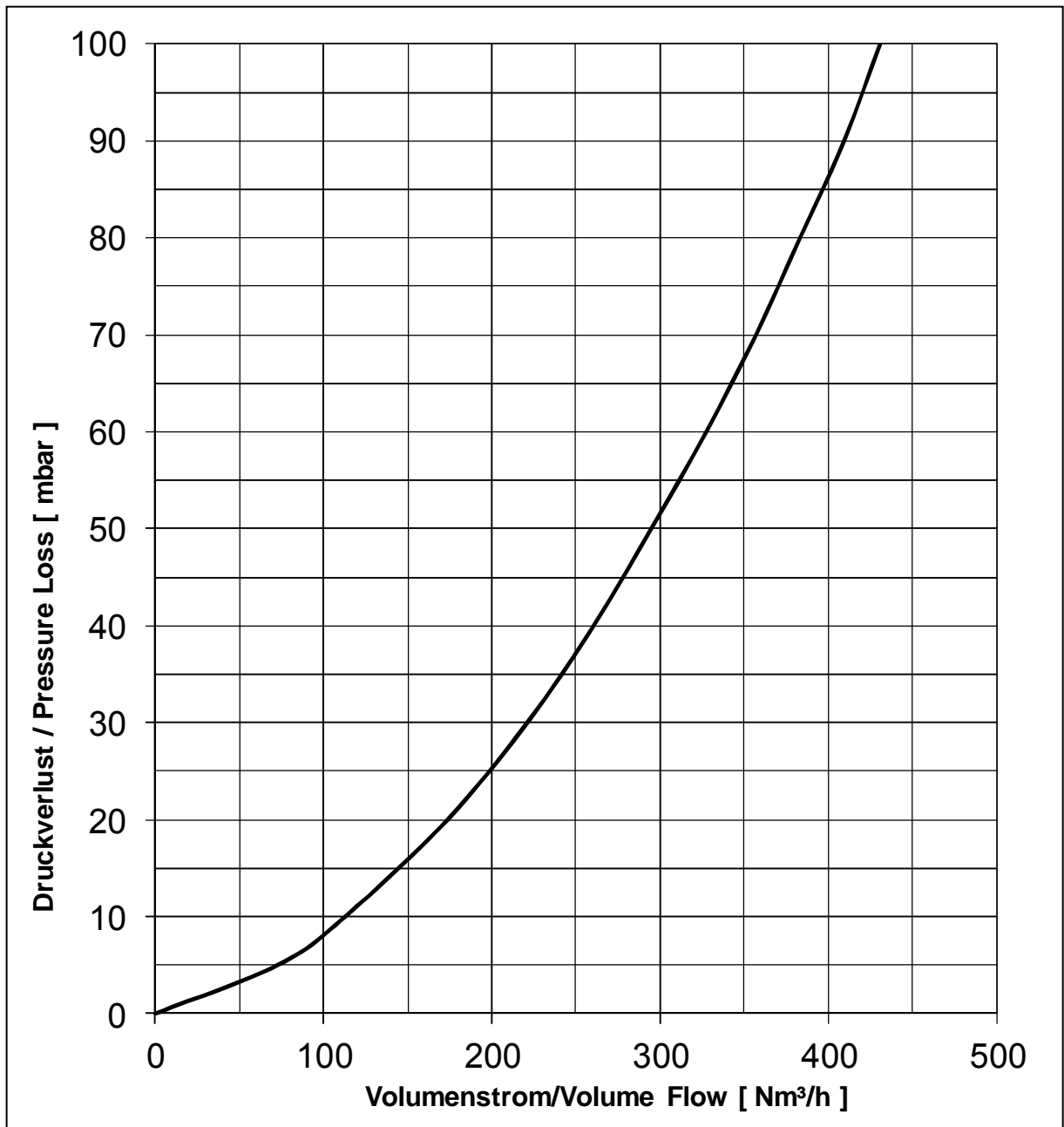

**Fig. 6**

Pressure loss 1008-0020 (DN 2 ½")

Medium : Air at  $p_o = 1013 \text{ mbar}$ ,  $T_o = 273\text{K}$ , density =  $1,293 \text{ kg/m}^3$

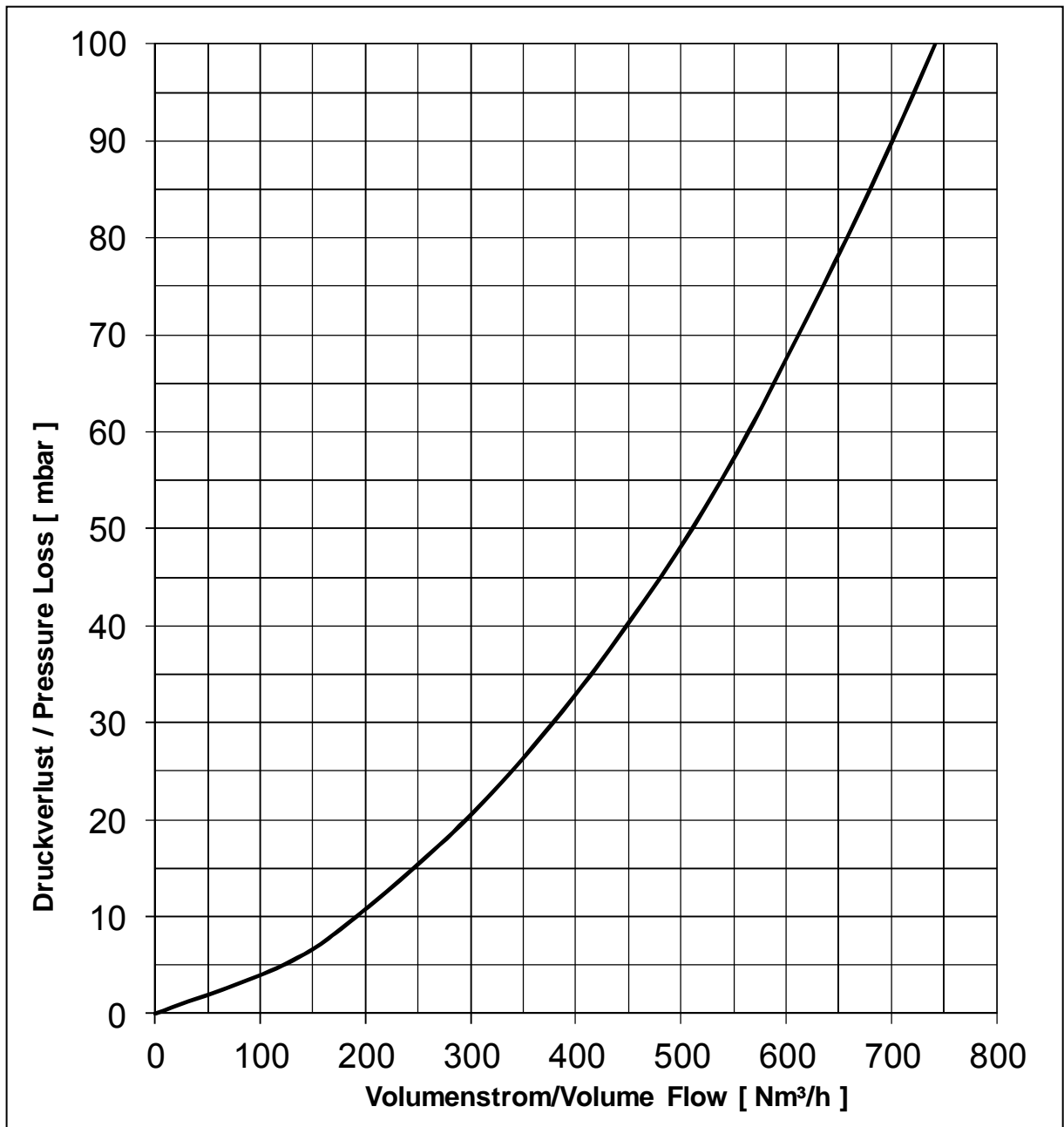

**Fig. 7**

Pressure loss 1008-0021 (DN 3")

Medium : Air at  $p_0 = 1013 \text{ mbar}$ ,  $T_0 = 273\text{K}$ , density =  $1,293 \text{ kg/m}^3$

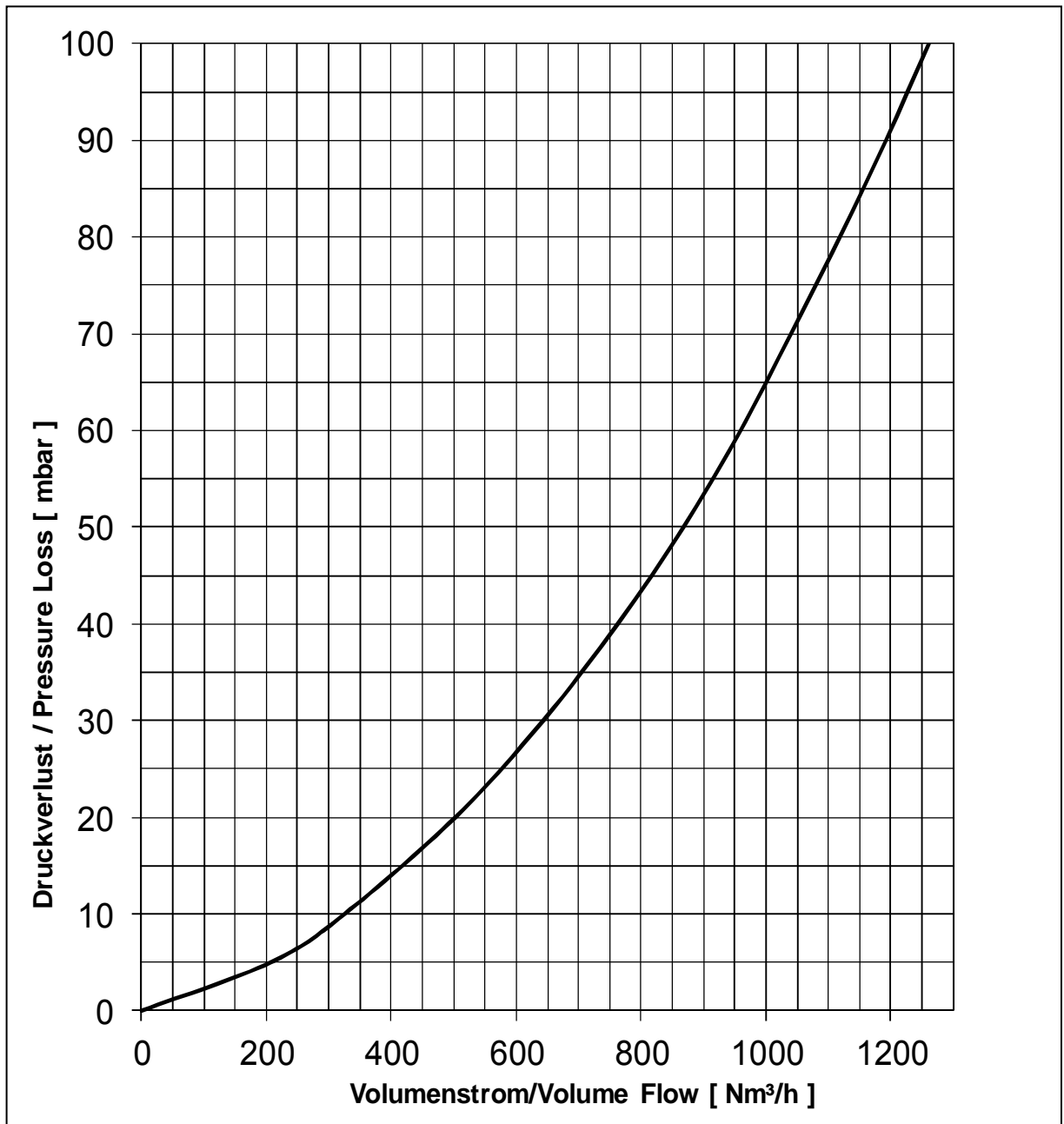

**Fig. 8**

Pressure loss 1008-0022 (DN 4")

Medium : Air at  $p_0 = 1013 \text{ mbar}$ ,  $T_0 = 273\text{K}$ , density =  $1,293 \text{ kg/m}^3$

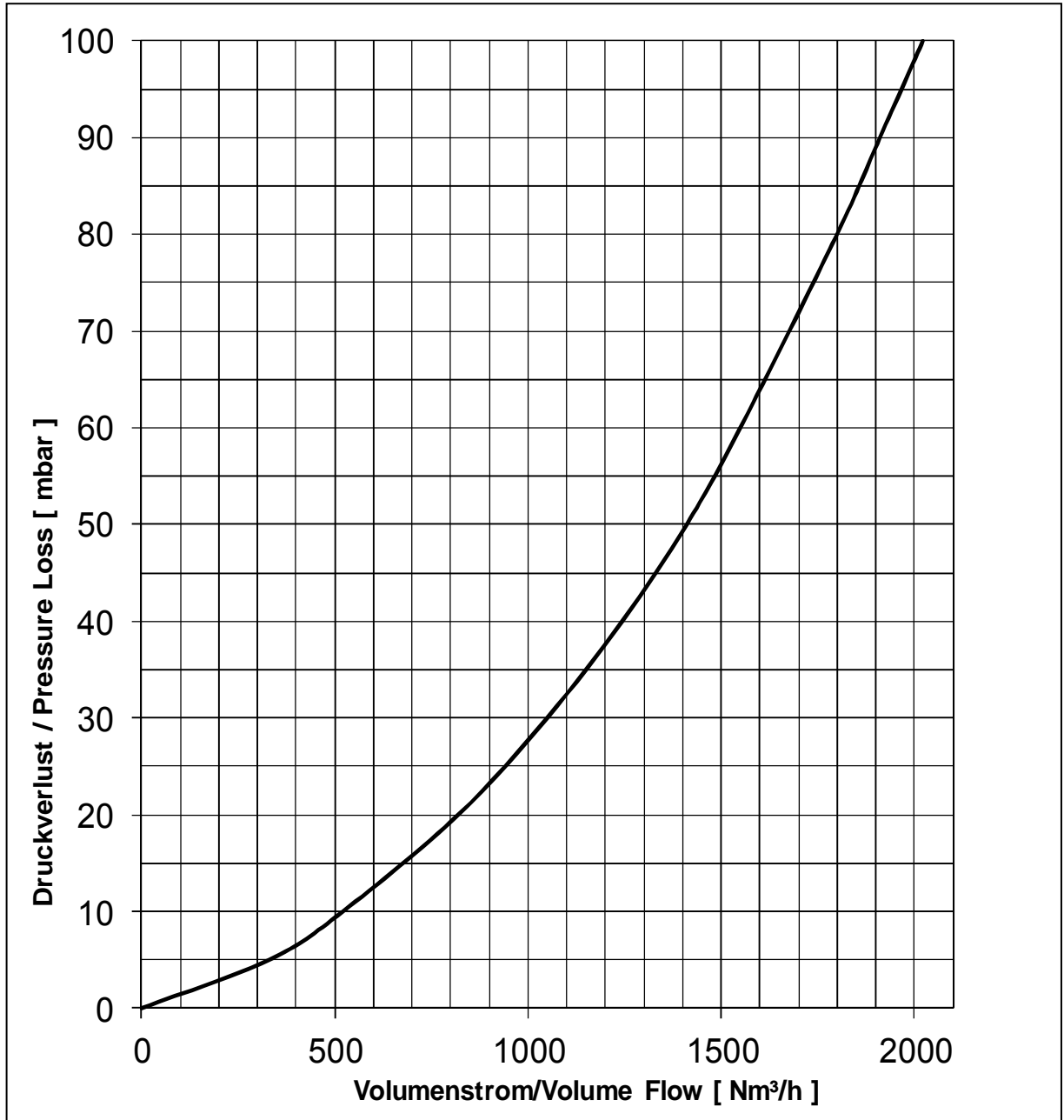

**Fig. 9**

Pressure loss 1008-0023 (DN 5")

Medium : Air at  $p_0 = 1013$  mbar,  $T_0 = 273$ K, density =  $1,293$  kg/m<sup>3</sup>

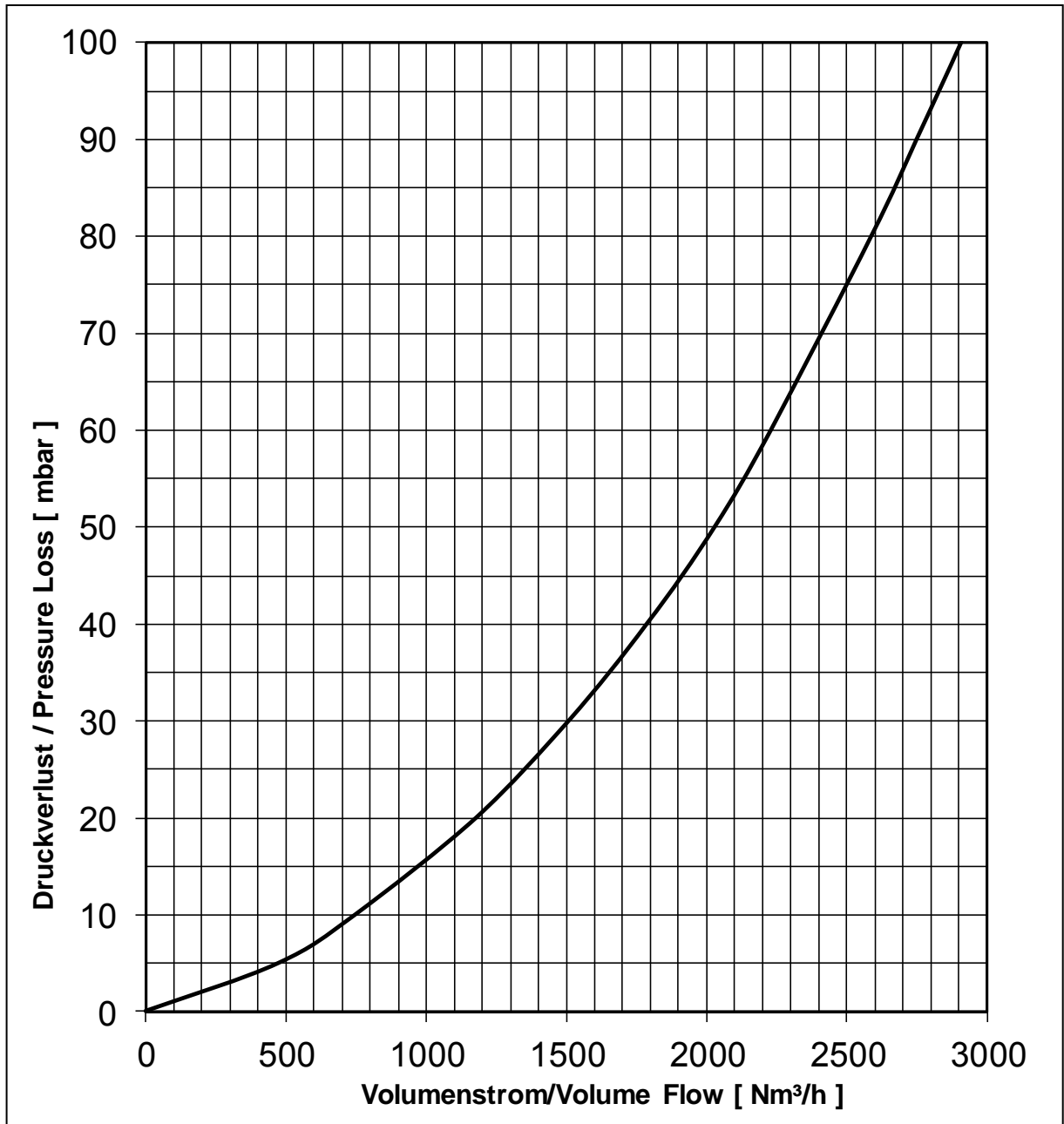

**Fig. 10**

Pressure loss 1008-0024 (DN 6")

Medium : Air at  $p_0 = 1013 \text{ mbar}$ ,  $T_0 = 273\text{K}$ , density =  $1,293 \text{ kg/m}^3$