

Operating Instruction

Foot Valve 1014-0004

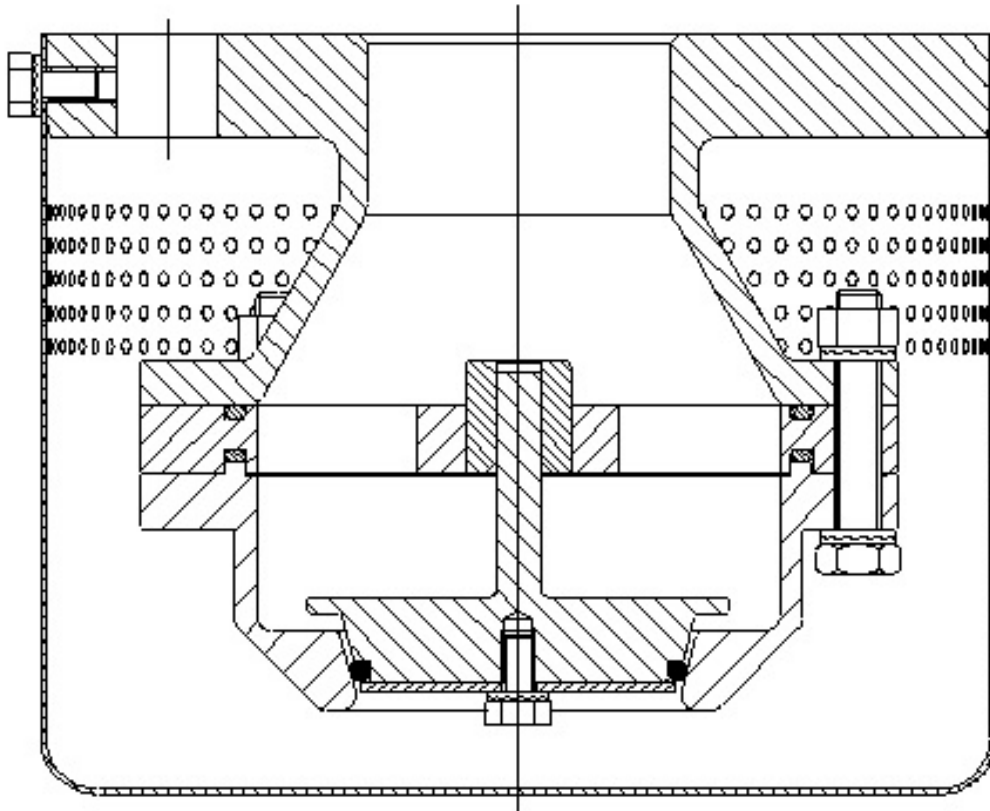

IBExU 17 ATEX 2085 X



G IIB3



1. Preface

These operating instructions apply to Foot Valve 1014-0004 provided the fact that your Foot Valve meet all technical standards described in this document.

Any information required for the assembly, use and maintenance of the protective system may be obtained from these instructions.

Please read the operating instructions on hand carefully to ensure the safe use of this Foot Valve.

All assembly and maintenance work needs to be carried out by qualified staff.

Information provided in this document may be subject to change without prior notice.

This document or individual parts of it may not be multiplied or copied without the written consent of Flammer GmbH, irrespective of its purpose.

© 2021 by Flammer GmbH. All rights reserved.

The trade names and/or used name designations, trademarks, etc. (even if not particularly identified), are subject to trademark protection laws and do not justify the assumption that they may be considered as fair use.

The operating instructions on hand correspond to the current technical state of Foot Valve 1014-0004. Content subject to change, errors excepted.

In case of dispute, the German text shall prevail.

2. Symbols



Pay attention to accompanying documents!
Important instructions for safe usage!

3. Safety regulations and safety instructions

3.1 Safety regulations

The following regulations and guidelines are to be observed for the use of this protection system:

- EC type examination number IBExU 17 ATEX 2085 X
- EN ISO 16852 Flame arresters
- European Directive 2014/34/EU
- Country-specific safety regulations
- Country-specific provisions for the protection of workers and employees

3.2 Safety instructions

The following instructions are to be observed to guarantee workers' protection and occupational safety:

- Safety regulations in compliance with section 3.1
- Compliance with laws and protective provisions in force at point of application. Operators and supervising staff are responsible for the fact that these provisions are observed.
- Assembly and maintenance work is to be carried out by qualified staff.

4. Intended application

Foot Valve type 1014-0004 prevents light-back at deflagration and stable detonation of potentially explosive vapor-air, and or gas-air mixtures of explosives group IIA1, IIA, IB1, IIB2 and IIB3 at an absolute working pressure $p_{abs} \leq 1.10$ bar in a pipe that is located upstream of the ignition source with a maximum nominal diameter of DN50 mm.



Warning!

Flame arresters are limited in mounting and use.

Pay attention to the following hints according to EN ISO 16852

Type	DET4		Detonation flame arrester for stable detonation without restriction
Lu/D	n/a		Pipe length not limited
BC	c		Not suitable for stabilized burning
EX	G IIB3		Explosion group
To	60	[°C]	Maximum operating temperature
po	1.10	[bar]	Maximum absolute operating pressure

4.1 Special requirements for safe use

- Maximum connector's nominal diameter DN : DN50
- Maximum pipe length between source of ignition and protective system : unrestricted
- Fitting position : vertical
- Combustible gases, i.e. combustible fluids that occur during operation have to be listed in explosives groups IIA1, IIA, IIB1, IIB2 or IIB3 with a standard gap (MESG) ≥ 0.65 mm.
- The Foot Valve only works in suction direction, e.g. the connection side = unprotected side has to be the suction side.
- The Foot Valve only works after total filling with the actual used liquid product for storage or transport.
- The Foot Valve is only usable for suction applications. It is to be ensured that the Foot Valve always remains filled.
- The Foot Valve may only be used, if the materials resist against the mechanical and/or chemical influences under the actual operating conditions, in such a way, that explosion protection is always guaranteed.

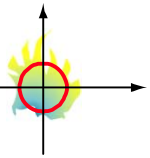

5. Technical specifications

(See also figure 1)

Connection : Flange DN50 EN 1092-1 Type 01 (DIN 2576) PN10(40)
Pressure loss : see fig. 2

6. Assembly

(See fig. 1)

Remove sieve cover **Pos.1** by disassembling the four screws **Pos.12**.

The Foot Valve 1014-0004 is to be fully connected by the flange onto the end of the suction pipe.

Reassemble sieve cover **Pos.1** in reverse order.



- Note requirements of chapter 4.
- Connections are to be sufficiently sealed with media resistant sealing and checked for leakage.
- Vertical mounting position.
- After assembling fill up sieve cover **Pos.1** completely with the liquid which shall be stored or transported.(For instance by submerging into the stored liquid)

7. Maintenance

To keep flow resistance at a constantly low level and ensure proper valve function, the Foot Valve is to be checked for impurities and, if necessary cleaned, in regular intervals.

Disassembling

Unscrew the 4 bolts **Pos.2** and remove the lid **Pos.1**.

For changing the O-Ring **Pos.7** a fully disassembling of the armature is necessary.

For this unscrew bolts **Pos.13, 14** and then bolt **Pos.2**. Remove washer **Pos.3**.



The O-Rings **Pos. 8** must be changed after fully disassembly.

Assembling

After cleaning, reassemble in reverse order.

Tightening moment M8: 20±2 Nm

Tightening moment M6: 8 ± 1 Nm



Attention!

- After assembly check all connections for leakage!
- Tighten screws **Pos.13, 14** with the required tightening moment **after 15 minutes again** because of PTFE O-Rings.
- The housing, especially the lid **Pos.1**, should be examined for corrosion which could cause leakage.
Damaged or leaky parts or the Foot Valve has to be exchanged by new ones.
Only use original spare parts of Flammer GmbH.
- After servicing fill up lid **Pos.1** completely with the liquid which shall be stored or transported.(For instance by submerging into the stored liquid)

After a detonation:

- Examine the Foot Valve for damages which could suspend explosion protection or proper valve function.
In case of e. g. leakage which could cause lost of the liquid buffer exchange damaged parts or the complete Foot Valve.
Only use original spare parts of Flammer GmbH.

8. Spare parts

For ordering spare parts please declare:

- Type of product
- Complete serial number
- Item number (Please refer to **fig. 1** for items)

9. Technical Consulting

Flammer GmbH
Daimlerstr. 3
D-74389 Cleebronn

Tel. : ++49 / (0) 7135 / 93 84 21 0
Fax. : ++49 / (0) 7135 / 93 84 21 99
E-mail : info@flammergmbh.de
Homepage : www.flammergmbh.com

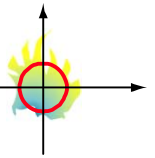

Connection side = Unprotected side

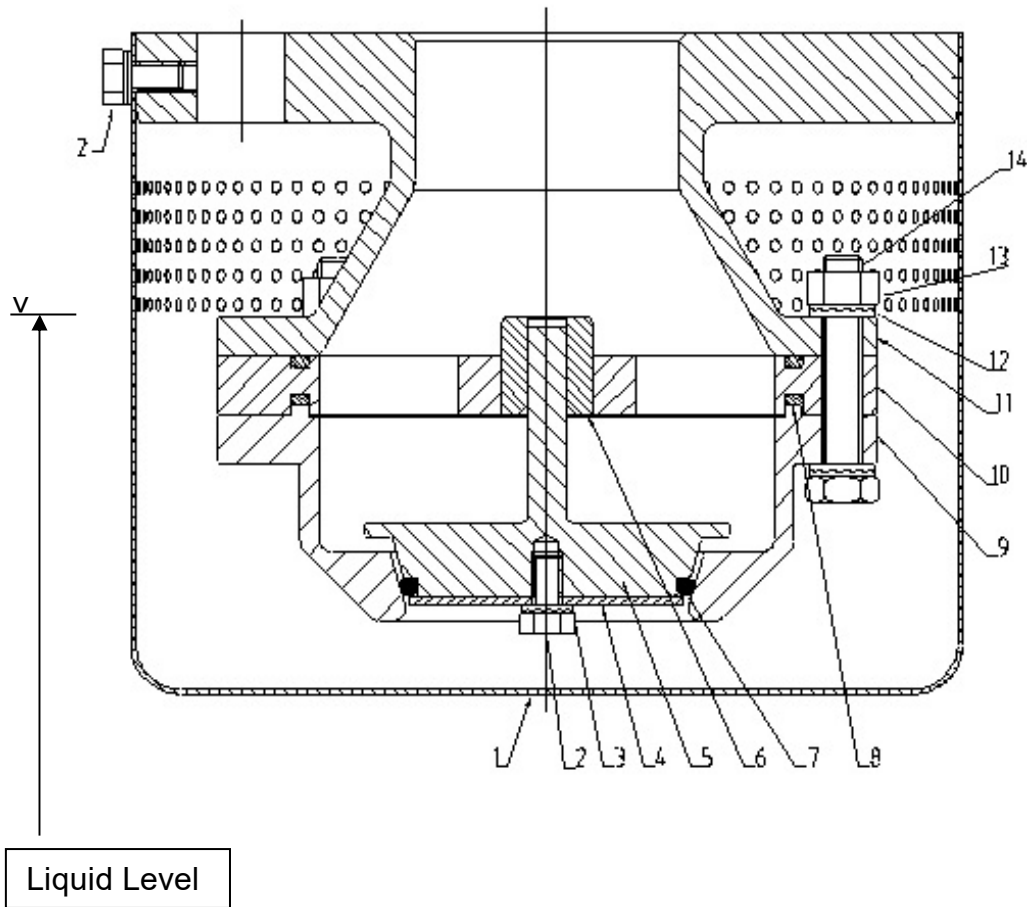

Fig. 1
Construction

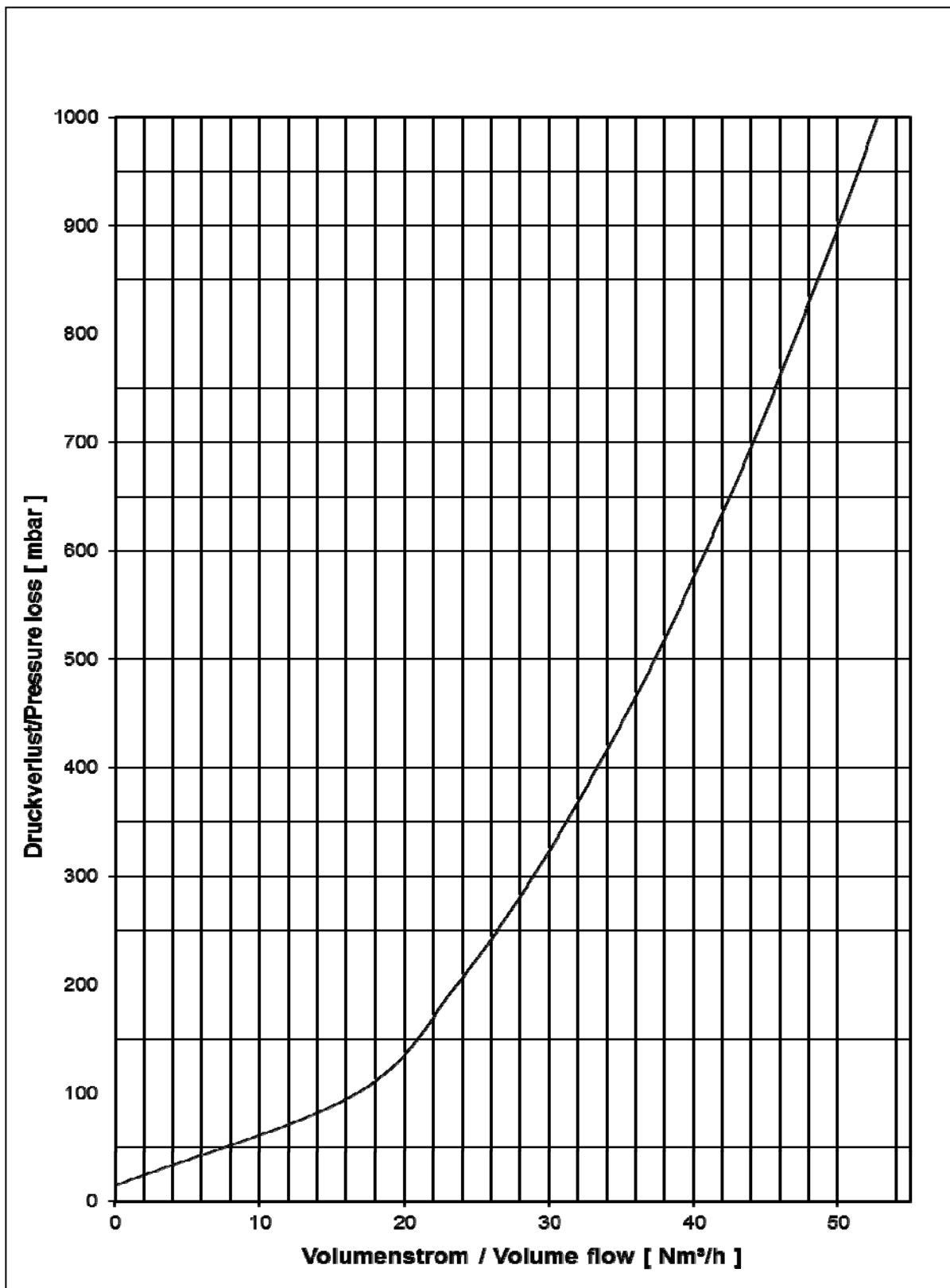
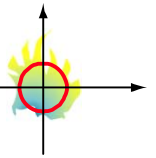

Fig. 2

Pressure loss

Medium : Water, density $\rho = 1000 \text{ kg/m}^3$, $t = 15^\circ\text{C}$