

Operating Instruction

Inline Detonation Flame Arrester 1002-0025

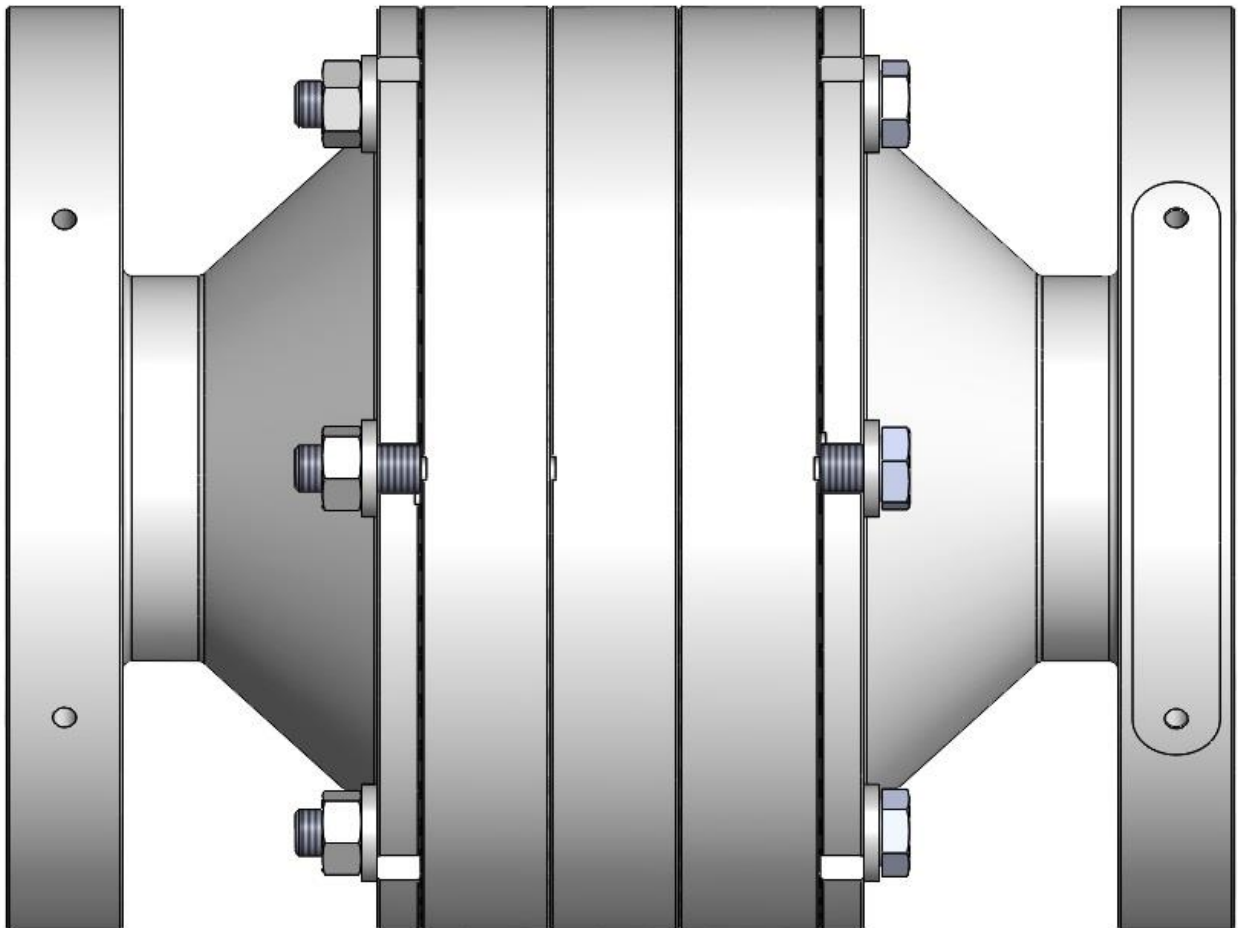

IBExU 21 ATEX 2109 X

 G IIC

 ⁰¹⁰²

1. Preface

These operating instructions apply to inline detonation flame arrester 1002-0025 provided the fact that your inline detonation flame arrester meet all technical standards described in this document.

Any information required for the assembly, use and maintenance of the protective system may be obtained from these instructions.

Please read the operating instructions on hand carefully to ensure the safe use of this inline detonation flame arrester.

All assembly and maintenance work needs to be carried out by qualified staff.

Information provided in this document may be subject to change without prior notice.

This document or individual parts of it may not be multiplied or copied without the written consent of Flammer GmbH, irrespective of its purpose.

© 2022 by Flammer GmbH. All rights reserved.

The trade names and/or used name designations, trademarks, etc. (even if not particularly identified), are subject to trademark protection laws and do not justify the assumption that they may be considered as fair use.

The operating instructions on hand correspond to the current technical state of inline detonation flame arrester 1002-0025. Content is subject to change, errors excepted. In case of dispute, the German text shall prevail.

2. Symbols



Pay attention to accompanying documents!
Important instructions for safe usage!

3. Safety regulations and safety instructions

3.1 Safety regulations

The following regulations and guidelines are to be observed for the use of this protection system:

- EC type examination number IBExU 21 ATEX 2109 X
- DIN EN ISO 16852 Flame arresters
- European Directive 2014/34/EU
- Country-specific safety regulations
- Country-specific provisions for the protection of workers and employees

3.2 Safety instructions

The following instructions are to be observed to guarantee workers' protection and occupational safety:

- Safety regulations in compliance with section 3.1
- Compliance with laws and protective provisions in force at point of application. Operators and supervising staff are responsible for the fact that these provisions are observed.
- Assembly and maintenance work is to be carried out by qualified staff.

4. Intended application and limits of use

Inline detonation flame arrester type 1002-0025 prevents light-back at deflagration and stable detonation of potentially explosive vapor-air, and or gas-air mixtures of explosives group IIA1, IIA, IIB1, IIB2, IIB3, IIB and IIC at an absolute operating pressure $p_{abs} \leq 1.20$ bar in a pipe that is located upstream of the ignition source presenting with a maximum nominal diameter of $DN = 50$ mm.



Warning!

Flame arresters are limited in mounting and use.

Pay attention to the following hints according to EN ISO 16852

Type	DET4		Inline detonation flame arrester for stable detonation without restriction
Lu/D	n/a		Length of pipe unlimited
BC	c		Not suitable for endurance burning
EX	G IIC		Explosion group
To	60	[°C]	Maximum operating temperature
po	1.20	[bar]	Maximum absolute operating pressure

4.1 Special requirements for safe use

- Maximum connected nominal pipe diameter DN : $\leq DN50$
- Maximum pipe unprotected length Lu : unrestricted
- Fitting position : user-defined
- Combustible gases, i.e. combustible fluids that occur during operation have to be listed in explosives groups IIA1, IIA, IIB1, IIB2, IIB3, IIB or IIC with a standard gap (MESG) up to < 0.50 mm.
- The inline detonation flame arrester is **not** tested for endurance burning and instable detonation and therefore is not authorized for that purpose!
- The inline detonation flame arrester is protecting against light-back on both sides, i.e. that it may be connected to either side of the side that is to be protected.
- The nominal pipe diameter on the unprotected side shall be no larger than the flame arrester connection.

The nominal pipe diameter on the protected side shall be no less than the pipe diameter on the unprotected side.

Nominal diameter unprotected side DN	Nominal diameter protected side DN
50	≥ 50
40	≥ 40

- The inline detonation flame arrester may only be used, if the materials resist against the mechanical and/or chemical influences under the actual operating conditions, in such a way, that explosion protection is always guaranteed. This applies particularly to the flame arrester elements whose protection against flame transmission may be endangered by corrosion among others.
- Shut off valves before and after the flame arrester must be fully open during normal operation.

5. Technical specifications

(See fig. 1)

Connection : Flange DN50 EN1092-1 (DIN 2576) PN10(16) or alike
 Other connection : on request
 Pressure loss : see fig. 2

6. Assembly

(See fig. 1).

The inline detonation flame arrester is to be fully and stressless joined to the respective connecting parts.



- Note requirements of chapter 4.
- The internal diameter of the connecting parts may not exceed the maximum permitted nominal pipe size.
- Any connection is to be sufficiently sealed with suitable media resistant sealing and checked for leakage. (Maximum test pressure $p_e = 12$ bar).
- Pay attention to professional earthing!
- Due to possible bimetallic corrosion (contact corrosion), we advise against use galvanized steel fittings in connection with stainless steel installations.

7. Maintenance

To keep flow resistance at a constantly low level, the inline detonation flame arrester is to be checked for impurities and, if necessary cleaned, in regular intervals.

Disassembling

Unscrew the bolts (Pos.2, 3) then remove a housing (Pos.1) and the flame arrester elements (Pos.5, 6) together with the distance racks (Pos.8). If O-ring (Pos.7) is damaged change it.

Petroleum ether is a suitable cleaning agent, although the instructions of the corresponding safety data sheet in accordance with directive 91/155/EC need to be observed.

Assembly

After cleaning, reassemble in reverse order.

First put flame arrester element (Pos. 6) on the housing (Pos.1) to ensure sealing of housing and following flame arrester elements (Pos.5)

Look out for the accurate number, order and position of the distance racks (Pos.8), the flame arrester elements (Pos.5, 6) and O-rings (Pos.7) to ensure function, a low pressure loss, a proper stabilisation of the flame arrester elements and a correct sealing.

For this the distance racks (Pos.8) should be in line with the stabilisation rack (Pos.9) of the housing.

The position of the distance and stabilisation racks is marked outside of the flame arrester elements and the housing by a groove. After assembly the following picture should be visible. In this case all parts are in the right position.

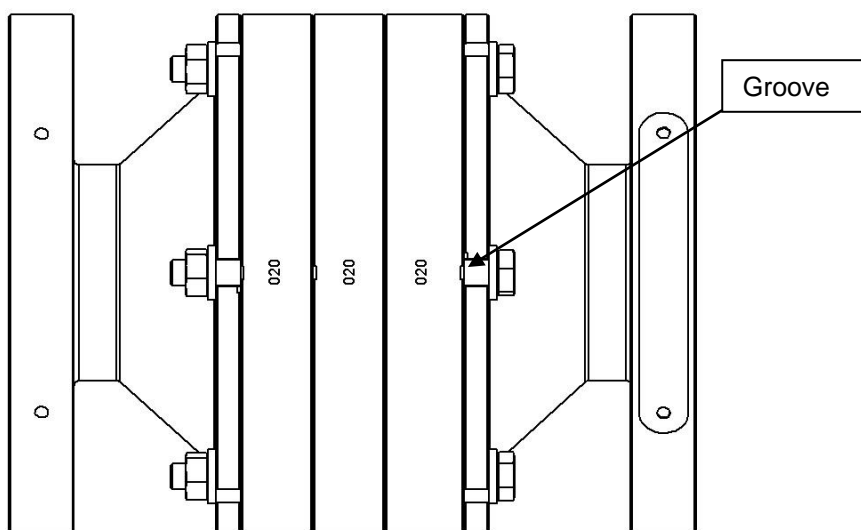

Tightening moment of nut M8 (Pos. 2, 3) : 20 ± 2 Nm



Note!

- Pay attention for the right gap width of the flame arrester element. The gap width (**0.20 mm**) is mentioned on the type label and every flame arrester element.(see fig. above)
- For safety reason it is not permitted to increase the gaps in the flame arrester elements (e.g. to drill).
- After assembly detonation flame arrester and connections have to be tested for leak tightness. (Maximum test pressure $p_e = 12$ bar).
- Tighten screws with the required tightening moment after 15 minutes again when using PTFE O-rings.

After a detonation:

- All parts (inside and outside) has to be examined and if necessary exchanged. Only use original spare parts of Flammer GmbH.
- In any case, replace flame arrester elements (Pos.5, 6) and O-ring (Pos. 7).

8. Spare parts

For ordering spare parts please declare:

- Type of product (REF)
- Complete serial number (SN)
- Spare part no. (Please refer to **fig. 1** for items)

Item	Product	Spare part no.
5, 6, 7	Spare part set	8001-0064
7	O – Ring	

9. Technical Consulting

Flammer GmbH
 Daimlerstr. 3
 D-74389 Cleebronn

Tel. : ++49 / (0) 7135 / 93 84 21 0
 Fax. : ++49 / (0) 7135 / 93 84 21 99
 E-mail : info@flammergmbh.de
 Homepage : www.flammergmbh.com

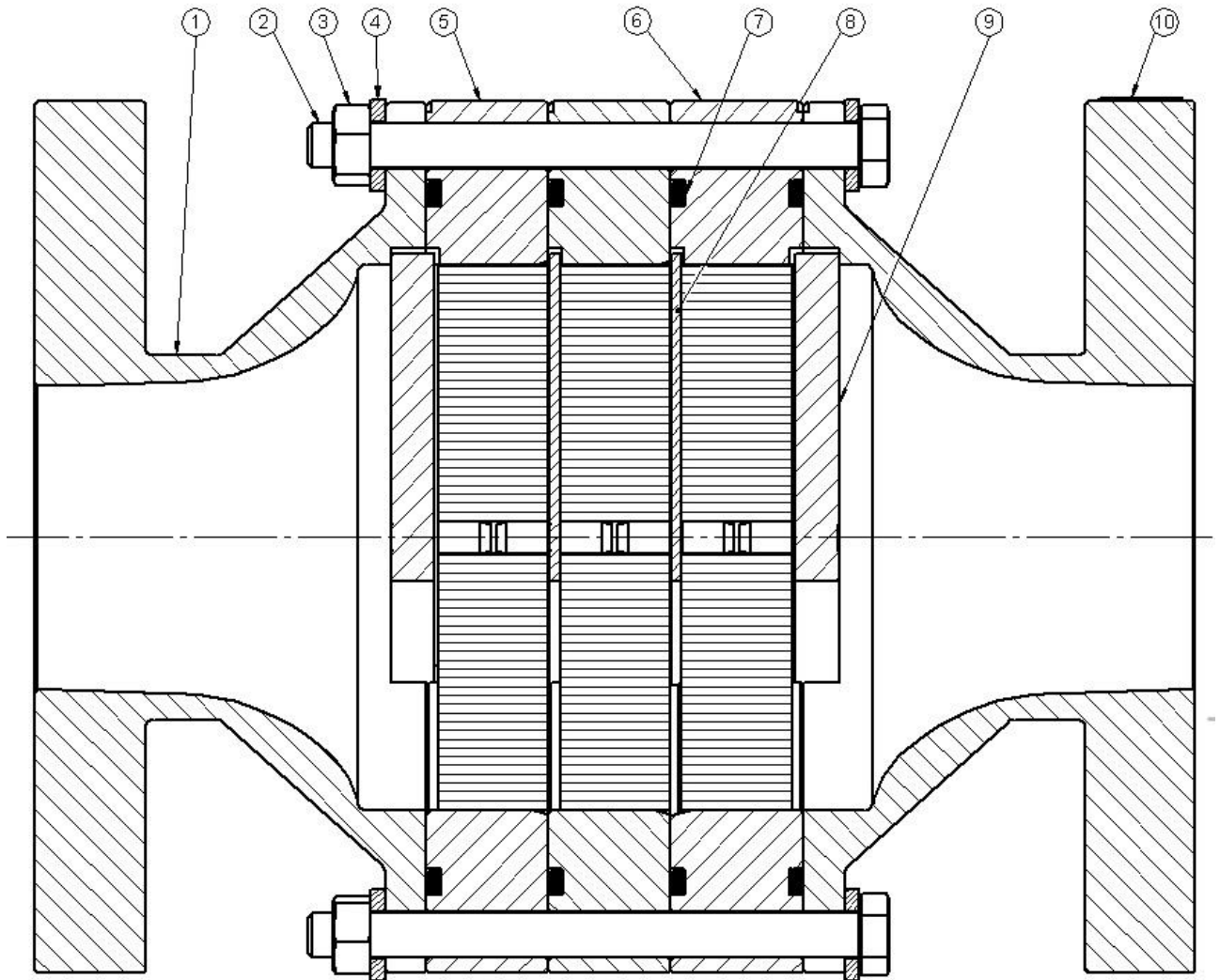

Fig. 1
Construction

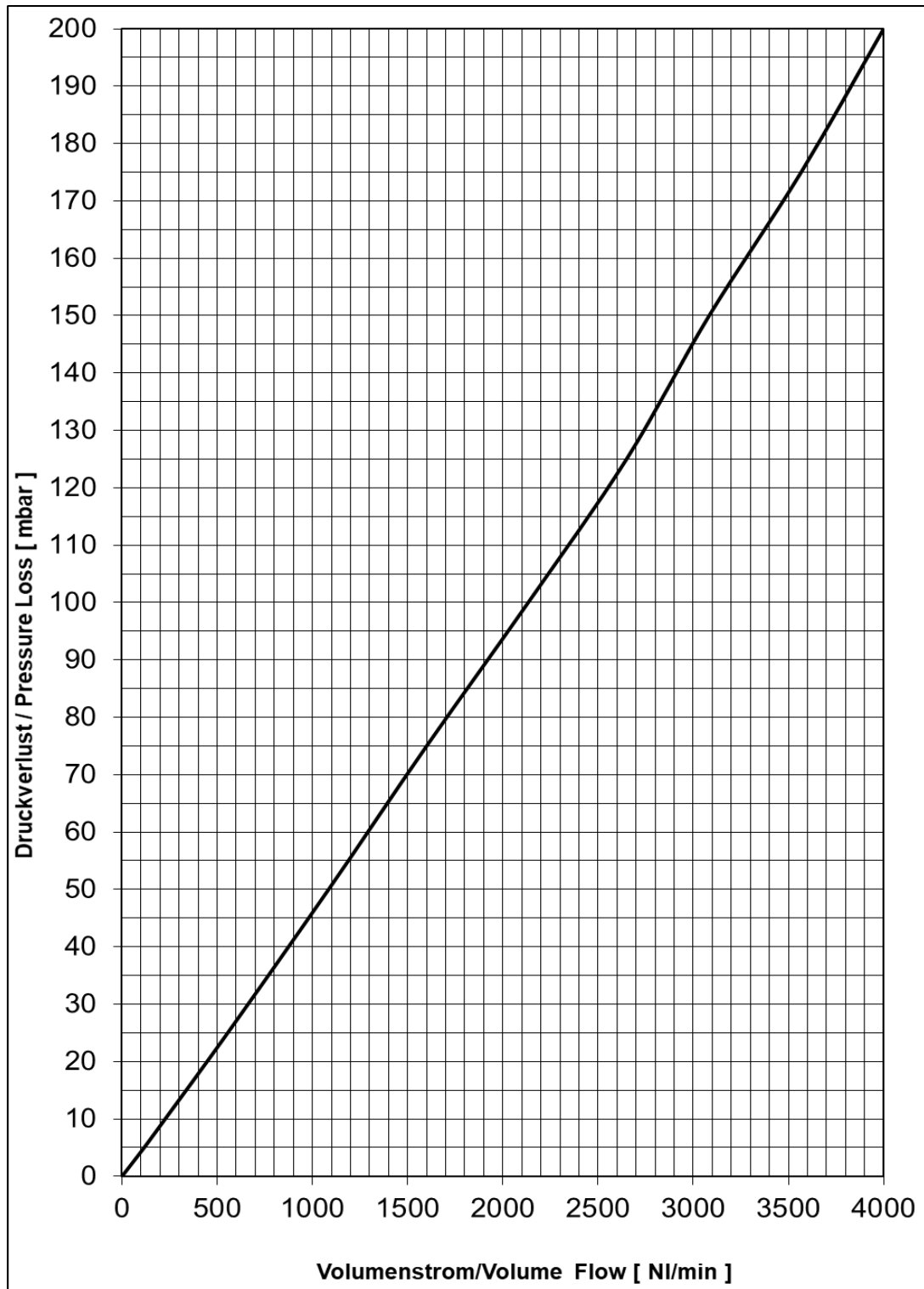

Fig. 2

Pressure loss

Medium : Air at $p_0 = 1013 \text{ mbar}$, $T_0 = 273\text{K}$, density = $1,293 \text{ kg/m}^3$