

Operating instruction Inline Deflagration Flame Arrester 1003-0018

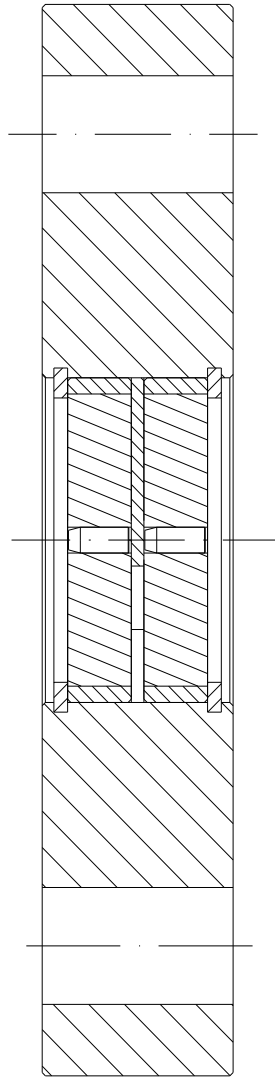

IBExU 08 ATEX 2155 X

 G IIA

Issue : 20.09.2022

www.flammergmbh.com



Page 1 of 7

1. Preface

These operating instructions apply to inline deflagration flame arrester 1003–0018 provided the fact that your inline deflagration flame arrester meet all technical standards described in this document.

Any information required for the assembly, use and maintenance of the protective system may be obtained from these instructions.

Please read the operating instructions on hand carefully to ensure the safe use of this deflagrations flame arrester.

All assembly and maintenance work needs to be carried out by qualified staff.

Information provided in this document may be subject to change without prior notice.

This document or individual parts of it may not be multiplied or copied without the written consent of Flammer GmbH, irrespective of its purpose.

© 2022 by Flammer GmbH. All rights reserved.

The trade and/or used name designations, trademarks, etc., even when not specially marked, do not justify the assumption that they may be considered as fair use, as defined by trademark protection laws.

These operating instructions correspond to the current technical state of inline deflagration flame arrester 1003-0018. Changes and errors excepted.

In case of dispute, the German text shall prevail.

2. Symbols



Take note of the accompanying documents!
Important instructions for safe usage

3. Safety regulations and safety instructions

3.1 Safety regulations

The following regulations and guidelines are to be observed for the use of this protective system:

- EC type examination number IBExU 08 ATEX 2155 X
- DIN EN ISO 16852 Flame arresters
- European Directive 2014/34/EU
- National safety regulations
- National workers' protection regulations

3.2 Safety instructions

The following instructions are to be observed to guarantee workers protection and occupational safety:

- Safety regulations in compliance with section 3.1
- Observation of laws and provisions in force at the place of application.
Operators and supervising staff are responsible for the fact that these provisions are observed.
- Assembly and maintenance work is to be carried out by qualified staff.

4. Purpose of use

Inline deflagration flame arrester type 1003-0018 prevents light-back at deflagration of potentially explosive vapour-air, and or gas-air mixtures of explosives group IIA1 and IIA with a standard gap > 0.90 mm at an absolute working pressure of pabs ≤ 1.20 bar in an ignition source preceding pipe with a maximum nominal diameter of DN = 50 mm and a corresponding maximum length of L = 2500 mm.(50*DN)



Warning!

Flame arresters are limited in mounting and use.

Pay attention to the following hints according to EN ISO 16852

Type	DEF		Deflagration flame arrester
Lu/D	50		Explanation see chapter 4.1
BC	c		Not suitable for endurance burning
EX	G IIA		Explosion group
To	60	[°C]	Maximum operating temperature
po	1.20	[bar]	Maximum absolute operating pressure

4.1 Special requirements for safe usage

- Max. nominal pipe diameter DN between the possible ignition source and the inline deflagration flame arrester : 50 mm
- Max. pipe length L (incl. connecting pieces) between the possible ignition source and the inline deflagration flame arrester : 2500 mm
- Max. pipe length L when connected pipe size is **smaller than DN 50** : 50*DN

Example :

*The allowed maximum pipe length is $L = 50 * DN = 1250$ mm for a connected internal pipe diameter of $DN = 25$ mm*

- Pipe branches and valves on the unprotected side shall be installed as close as possible to the in-line deflagration flame arrester.
- Combustible gases and or liquids produced during operation must pertain to explosives group IIA1 or IIA with a standard gap (MESG) > 0.90 mm.
- Shut off valves before and after the flame arrester has to be fully open during normal operation.
- The nominal pipe diameter on the unprotected side shall be no larger than the flame arrester connection.
The nominal pipe diameter on the protected side shall be no less than the pipe diameter on the unprotected side.
- The in-line deflagration flame arrester is bi-directional, i.e. that it may be connected to either side of the system.
- The in-line deflagration flame arrester may be fitted in any position.
- The end of line - and inline deflagration flame arrester is not tested and authorised for endurance burning.
- The inline deflagration flame arrester may only be used, if the materials resist against the mechanical and/or chemical influences under the actual operating conditions, in such a way, that explosion protection is always guaranteed.
This applies particularly to the flame arrester elements whose protection against flame transmission may be endangered by corrosion among others.

5. Technical specifications

(See figure 2)

Connection : Flange DN50 EN1092-1 (DIN2576) PN10
 Pressure loss : see fig. 1

6. Assembly

(See figure 2)

The deflagration flame arrester is to be fully joined to the respective connecting parts.



- Note requirements of chapter 4.
- The internal diameter of the connecting parts may not exceed the maximum permitted nominal pipe size.
- Any connection is to be sufficiently sealed with suitable media resistant sealing and checked for leakage.
- Due to possible bimetallic corrosion (contact corrosion), we advise against use galvanized steel fittings in connection with stainless steel installations.

7. Maintenance

To keep flow resistance at a constantly low level, the inline deflagration flame arrester is to be checked for impurities and, if necessary cleaned, in regular intervals.

Petroleum ether could be a suitable cleaning agent, although the instructions of the corresponding safety data sheet in accordance with directive 91/155/EC need to be observed.

Disassembling

(see fig.2)

Remove one retaining ring (Pos.2) then flame arrester elements (Pos.3) together with the spacer (Pos.4).

Assembly

After cleaning, reassemble in reverse order.



- Take note for the right order of the flame arrester elements (Pos.3) and the spacer (Pos.4)
- For safety reason it is not permitted to increase the gaps in the flame arrester elements (e.g. to drill).
- After reassembling check connections for leakage!

After a deflagration:

- All parts (inside and outside) has to be examined and if necessary exchanged.
- In any case, replace flame arrester elements (Pos.3).

8. Spare parts

For ordering spare parts please declare:

- Type of product
- Complete serial number
- Spare part no. (Please refer to **fig. 2** for items)

Pos.	Name	Order no.
3,4	Spare set	8001-0005-00

9. Technical Consultations

Flammer GmbH
Daimlerstr. 3
D-74389 Cleebronn

Tel. : ++49 / (0) 7135 / 93 84 21 0
Fax. : ++49 / (0) 7135 / 93 84 21 99
E-Mail : info@flammergmbh.de
Homepage : www.flammergmbh.com

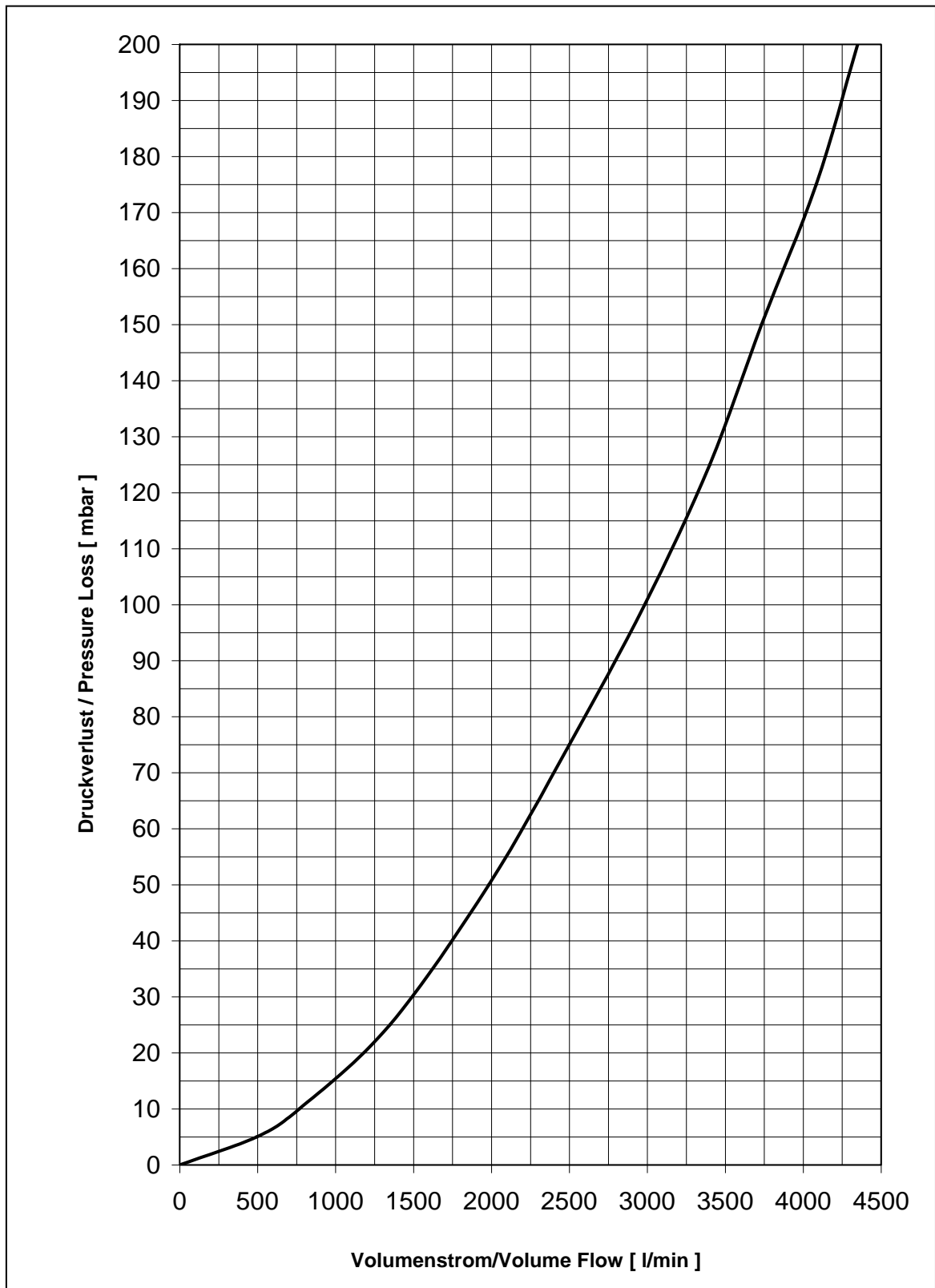

Fig. 1

Pressure loss

Medium : Air at $p_0 = 1013 \text{ mbar}$, $T_0 = 273\text{K}$, density = $1,293 \text{ kg/m}^3$

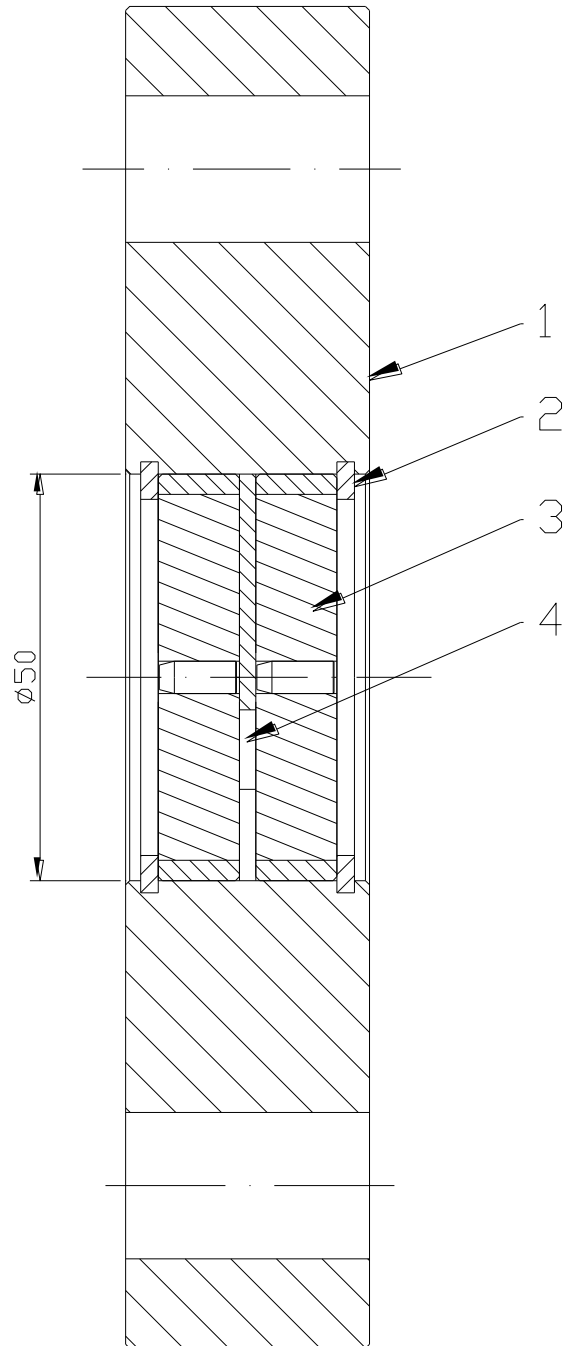

Fig. 2
Construction