

Operating Instruction

Inline Deflagration Flame Arrester 1003-0020

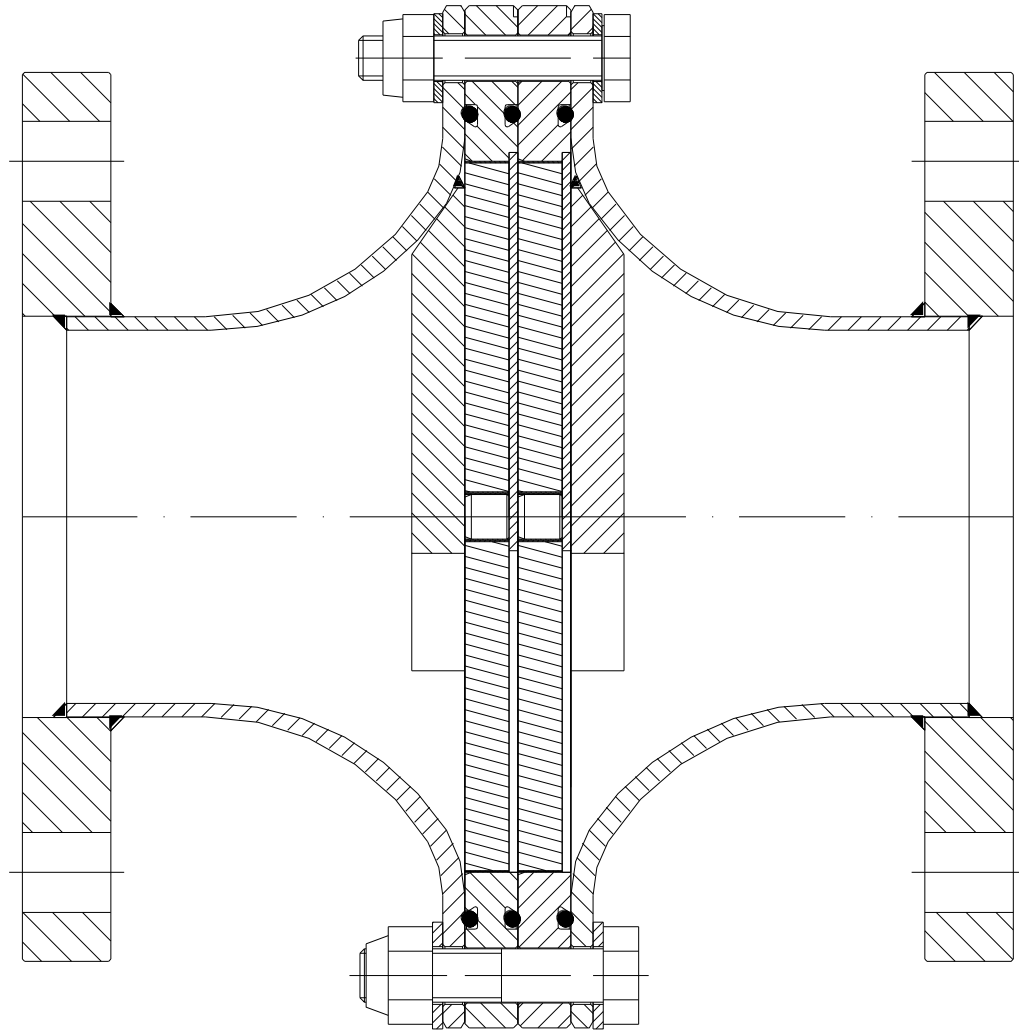

IBExU 14 ATEX 2024 X

 G IIB

 ⁰¹⁰²

1. Preface

This operating instruction apply to inline deflagration flame arrester 1003-0020, provided the fact that your in-line deflagration flame arrester meets all technical standards described in this document.

Any information required for the assembly, use and maintenance of the protective system may be obtained from these instructions.

Please read the operating instructions on hand carefully to ensure the safe use of this in-line deflagration flame arrester.

All assembly and maintenance work needs to be carried out by qualified staff.

Information provided in this document may be subject to change without prior notice.

This document or individual parts of it may not be multiplied or copied without the written consent of Flammer GmbH, irrespective of its purpose.

© 2022 by Flammer GmbH. All rights reserved.

The trade and/or used name designations, trademarks, etc., even when not specially marked, do not justify the assumption that they may be considered as fair use, as defined by trademark protection laws.

The operating instructions on hand correspond to the current technical state of inline deflagration flame arrester 1003-0020. Content is subject to change. Errors excepted.

In case of dispute, the German text shall prevail.

2. Symbols



Take note of the accompanying documents!
Important instructions for safe usage

3. Safety regulations and safety instructions

3.1 Safety regulations

The following regulations and guidelines are to be observed for the use of this protective system:

- EC type examination number IBExU 14 ATEX 2024 X
- DIN EN ISO 16852 Flame arresters
- European Directive 2014/34/EU
- National safety regulations
- National workers' protection regulations

3.2 Safety instructions

The following instructions are to be observed to guarantee workers protection and occupational safety:

- Safety regulations in compliance with section 3.1
- Observation of laws and provisions in force at the place of application.
Operators and supervising staff are responsible for the fact that these provisions are observed.
- Assembly and maintenance work is to be carried out by qualified staff.

4. Purpose of use

Inline deflagration flame arrester type 1003-0020 prevents light-back at deflagration of potentially explosive vapour-air, and or gas-air mixtures of explosives group IIA1, IIA, IIB1, IIB2, IIB3 or IIB (Safe gap (MESG) ≥ 0.50 mm) at an absolute working pressure of pabs ≤ 1.20 bar in an ignition source preceding pipe with a maximum nominal diameter of DN = 100 mm and a corresponding maximum length of L = 3000 mm.



Warning!

Flame arresters are limited in mounting and use.

Pay attention to the following hints according to EN ISO 16852

Type	DEF		Deflagration flame arrester
Lu/D	30		Explanation see chapter 4.1
BC	c		Not suitable for endurance burning
EX	G IIB		Explosion group
To	60	[°C]	Maximum operating temperature
po	1.20	[bar]	Maximum absolute operating pressure

4.1 Special conditions for safe usage

- Max. nominal pipe diameter DN between : 100 mm
the possible ignition source and the inline deflagration flame arrester
- Max. pipe length L (incl. connecting pieces) between : 30*DN
the possible ignition source and the in-line deflagration flame arrester.

Example:

The allowed maximum pipe length is $L = 30 \cdot DN = 2400$ mm for a connected nominal pipe diameter of $DN = 80$ mm

- The nominal pipe diameter on the unprotected side shall be no larger than the flame arrester connection.
The nominal pipe diameter on the protected side shall be no less than the pipe diameter on the unprotected side.
- The Inline deflagration flame arrester may only be used, if the materials resist against the mechanical and/or chemical influences under the actual operating conditions, in such a way, that explosion protection is always guaranteed. This applies particularly to the flame arrester elements whose protection against flame transmission may be endangered by corrosion among others.
- Pipe branches and valves on the unprotected side shall be installed as close as possible to the inline deflagration flame arrester.
- The in-line deflagration flame arrester is bi-directional, i.e. that it may be connected to either side of the system.
- The in-line deflagration flame arrester may be fitted in any position.
- Combustible gases and or liquids produced during operation must pertain to explosives group IIA1, IIA, IIB1, IIB2, IIB3 or IIB with a safe gap (MESG) ≥ 0.50 mm.
- The inline deflagration flame arrester is **not** tested and authorised for endurance burning.
- Shut off valves before and after the flame arrester has to be fully open during normal operation.

5. Technical specifications

(See figure 1)

Connection : Flange DN100 EN1092-1 (DIN 2576) PN10(16) or alike
 Pressure loss : see fig. 2

6. Assembly

(See figure 1)

The inline deflagration flame arrester is to be fully and stressless joined to the respective connecting parts.



- Note requirements of chapter 4.
- The internal diameter of the connecting parts may not exceed the maximum permitted nominal pipe size.
- Any connection is to be sufficiently sealed with suitable media resistant sealing and checked for leakage. (Maximum test pressure $p_e = 12$ bar).
- Pay attention to professional earthing!
- Due to possible bimetallic corrosion (contact corrosion), we advise against use galvanized steel fittings in connection with stainless steel installations.

7. Maintenance

To keep flow resistance at a constantly low level, the in-line deflagration flame arrester is to be checked for impurities and, if necessary cleaned, in regular intervals.

Disassembling

Unscrew the bolts (Pos.3, 7, 11, 13) then remove a housing (Pos.2) and the flame arrester elements (Pos.5, 6) together with the distance racks (Pos.9). If O-rings (Pos.8) are damaged change them.

Petroleum ether is often a suitable cleaning agent, although the instructions of the corresponding safety data sheet in accordance with directive 91/155/EC need to be observed.

Assembly

After cleaning, reassemble in reverse order.

Look out for the accurate position of the distance rack (Pos.9) to ensure a low pressure loss and a proper stabilisation of the flame arrester element.

For this the distance rack (Pos.9) should be in line with the stabilisation rack of the housing (Pos.10).

The distance rack (Pos.9) has a key which fits to a groove of the flame arrester elements (Pos.5, 6).

The groove and the stabilisation rack (Pos. 10) are in line with the bolt bore $\varnothing 13$.

The position of the bore $\varnothing 13$ is marked outside of the flame arrester element by a second groove. After assembly the following picture should be visible while looking from above onto the bolt M12 (Pos. 3, 7). In this case all parts are in the right position.

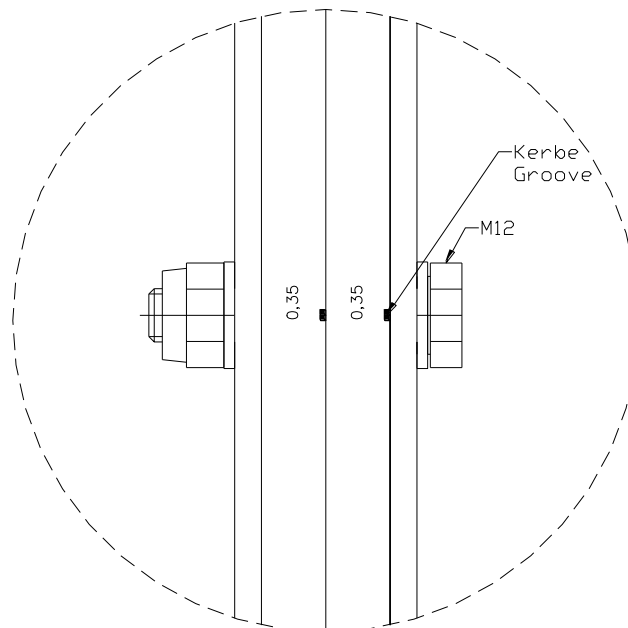

Tightening moment of nut M12 (pos. 3, 7) : 60 ± 2 Nm

Tightening moment of nut M16 (pos. 11, 13) : 140 ± 2 Nm



Note!

- Pay attention for the right gap width of the flame arrester element.
The gap width (**$\Delta 0,35$**) is mentioned on the type label and every flame arrester element.(see fig. above)
- For safety reason it is not permitted to increase the gaps in the flame arrester elements (e.g. to drill).
- After assembly inline deflagration flame arrester and connections have to be tested for leak tightness. (Maximum test pressure $p_e = 12$ bar).
- Tighten screws with the required tightening moment after 15 minutes again when using PTFE O-rings.

After a deflagration:

- All parts (inside and outside) has to be examined and if necessary exchanged.
- In any case flame arrester elements (pos.5, 6) should be replaced.

8. Spare parts

For ordering spare parts please declare:

- Type of product
- Complete serial number
- Spare part no. (Please refer to **fig. 1** for items)

Item	Product	Spare part no.
5, 6, 8, 9	Spare part set	8001-0046
8	O-Ring	

9. Technical Consultations

Flammer GmbH
Daimlerstr. 3
D-74389 Cleebronn

Tel. : ++49 / (0) 7135 / 93 84 21 0
Fax. : ++49 / (0) 7135 / 93 84 21 99
E-mail : info@flammergmbh.de
Homepage : www.flammergmbh.com

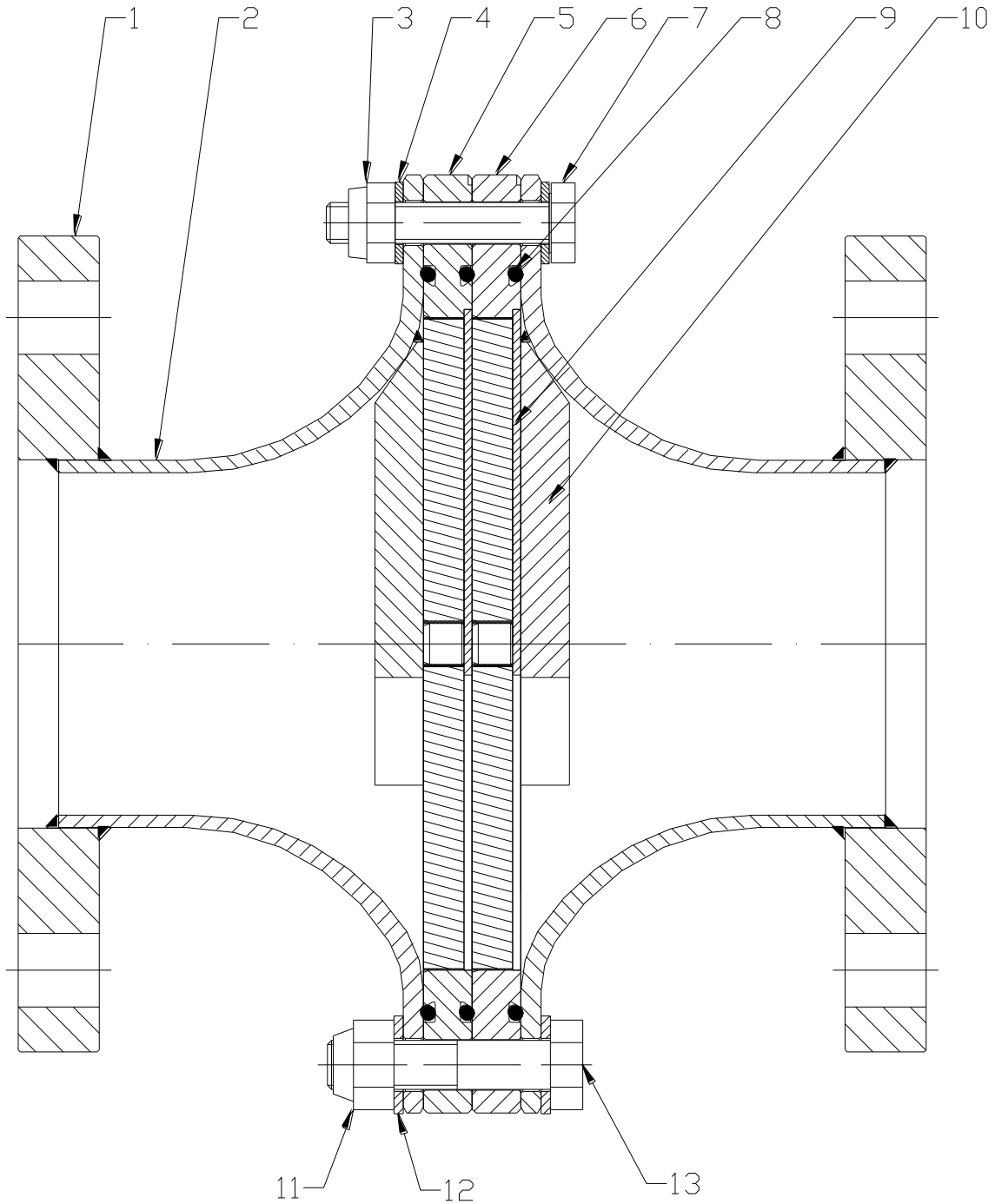

Fig. 1
Construction

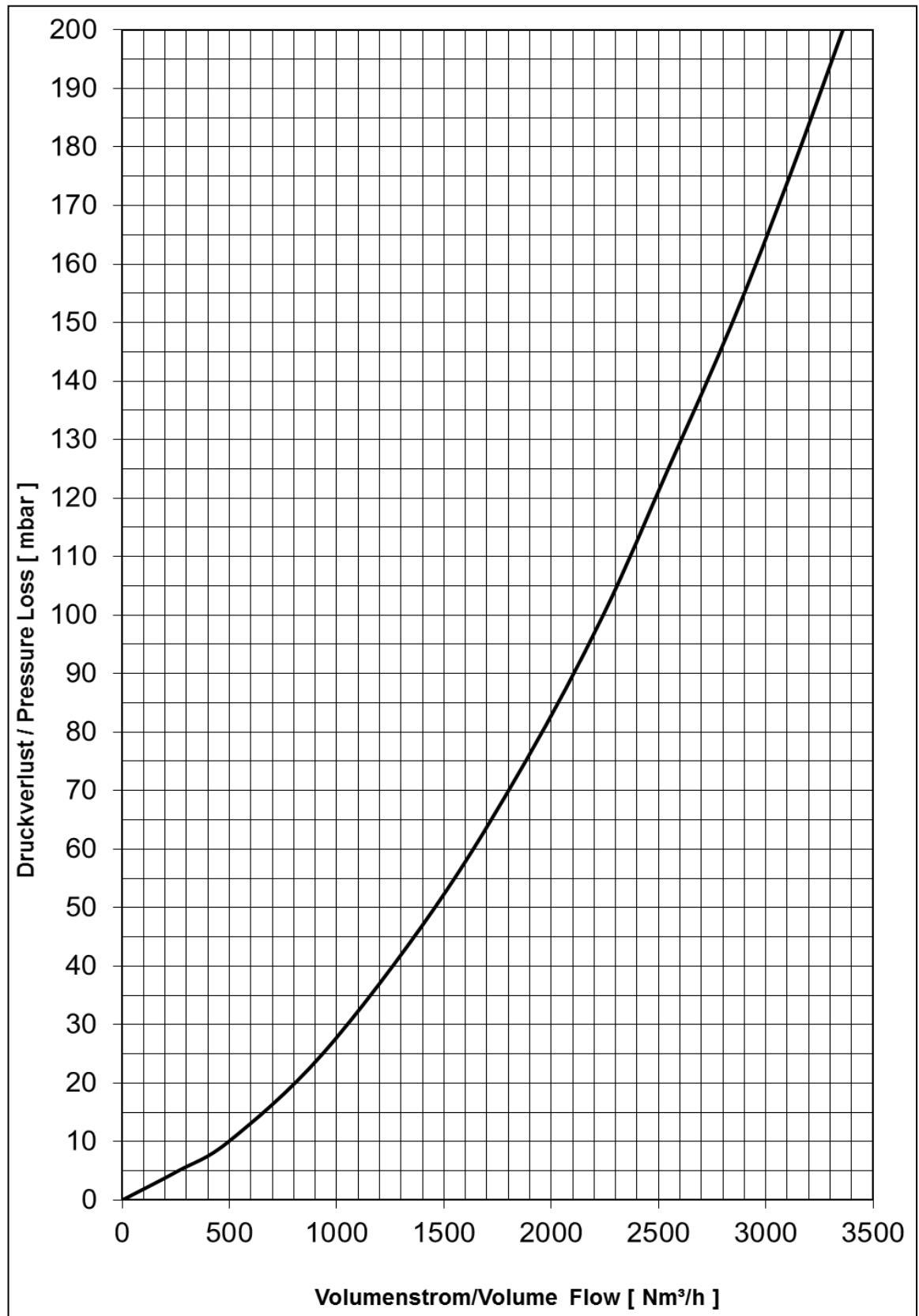

Fig. 2

Pressure loss

Medium : Air at $p_0 = 1013 \text{ mbar}$, $T_0 = 273\text{K}$, density = $1,293 \text{ kg/m}^3$