

Operating Instruction

End of line Deflagration Flame Arrester 1008-0014

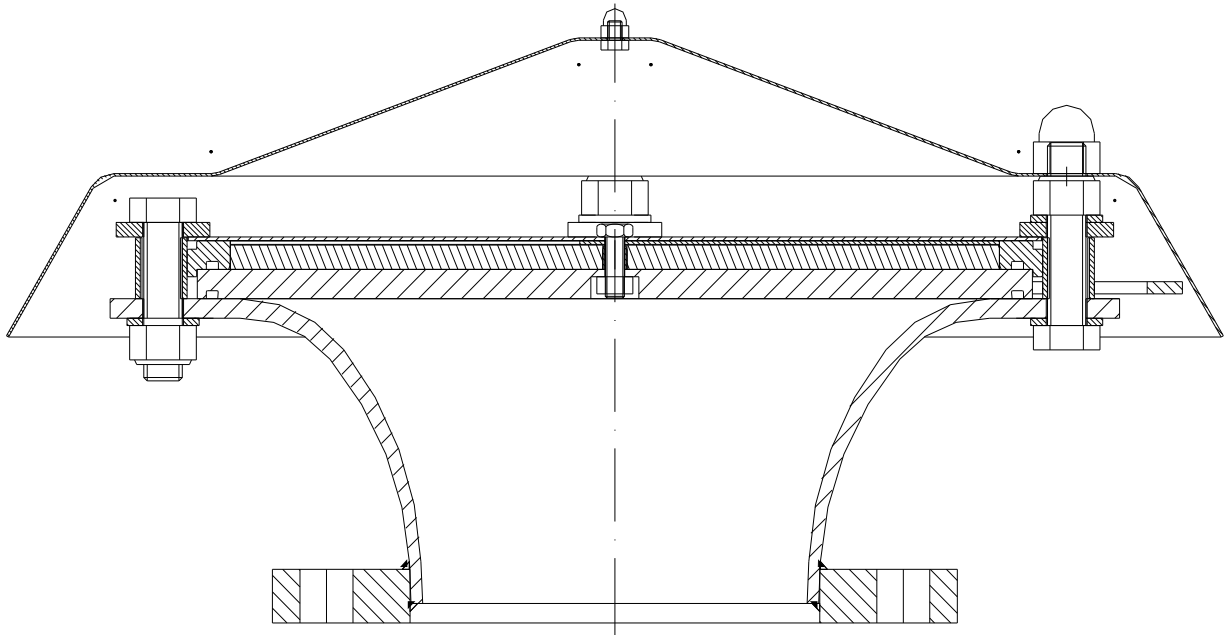

IBExU 12 ATEX 2140 X

 G IIB



1. Preface

This operating instruction apply to end of line deflagration flame arrester 1008–0014, provided the fact that your end of line deflagration flame arrester meets all technical standards described in this document.

The protective system is **not** tested and authorised for endurance burning.

Any information required for the assembly, use and maintenance of the protective system may be obtained from these instructions.

Please read the operating instructions on hand carefully to ensure the safe use of this protective system.

All assembly and maintenance work needs to be carried out by qualified staff.

Information provided in this document may be subject to change without prior notice.

This document or individual parts of it may not be multiplied or copied without the written consent of Flammer GmbH, irrespective of its purpose.

© 2022 by Flammer GmbH. All rights reserved.

The trade and/or used name designations, trademarks, etc., even when not specially marked, do not justify the assumption that they may be considered as fair use, as defined by trademark protection laws. Changes and errors excepted.

In case of dispute, the German text shall prevail.

2. Symbols



Take note of the accompanying documents!
Important instructions for safe usage

3. Safety regulations and safety instructions

3.1 Safety regulations

The following regulations and guidelines are to be observed for the use of this protective system:

- EC type examination number IBExU 12 ATEX 2140 X
- EN ISO 16852 Flame arresters
- European Directive 2014/34/EU
- National safety regulations
- National workers' protection regulations

3.2 Safety instructions

The following instructions are to be observed to guarantee workers protection and occupational safety:

- Safety regulations in compliance with section 3.1
- Observation of laws and provisions in force at the place of application.
Operators and supervising staff are responsible for the fact that these provisions are observed.
- Assembly and maintenance work is to be carried out by qualified staff.

4. Purpose of use

The end of line deflagration flame arrester 1008-0014 at the end of vent pipes prevents light-back at deflagration of potentially explosive vapour-air, and or gas-air mixtures of explosives group IIA1, IIA, IIB1, IIB2, IIB3 and IIB with a standard gap (MESG) ≥ 0.50 mm from outside (atmospheric conditions) to the protected side (e. g. storage tank).



Warning!

Flame arresters are limited in mounting and use.

Pay attention to the following hints according to EN ISO 16852

Type	DEF		Deflagration flame arrester
Lu/D	n/a		Not applicable
BC	c		Not suitable for endurance burning
EX	G IIB		Explosion group
To	60	[°C]	Maximum operating temperature
po	1.10	[bar]	Atmospheric conditions

4.1 Special requirements for safe usage

- Max. internal nominal pipe diameter DN : DN150 (6")
- The protective system has to be fitted in vertical position.
- Combustible gases and or liquids produced during operation must pertain to explosives group IIA1, IIA, IIB1, IIB2, IIB3 or IIB with a standard gap (MESG) ≥ 0.50 mm.
- The protective system is **not tested** and authorised for endurance burning!
- The protective system may only be used, if the materials resist against the mechanical and/or chemical influences under the actual operating conditions, in such a way, that explosion protection is always guaranteed. This applies particularly to the flame arrester elements whose protection against flame transmission may be endangered by corrosion among others.

5. Technical specifications

(See fig.1)

Connection : Flange on request.

Pressure loss : see fig. 2

6. Assembly

(See figure 1)

The deflagration flame arrester is to be fully joined to the respective connecting parts.



- Note requirements of chapter 4.
- The internal diameter of the connecting parts may not exceed the maximum permitted nominal pipe size.
- Any connection is to be sufficiently sealed with suitable media resistant sealing and checked for leakage.
- Look out for sufficient electrical grounding.
- Due to possible bimetallic corrosion (contact corrosion), we advise against use galvanized steel fittings in connection with stainless steel installations.

7. Maintenance

To keep flow resistance at a constantly low level, the protective system is to be checked for impurities and, if necessary cleaned, in regular intervals.

Disassembling

Unscrew nut (13) to remove rain cover (9). Take off the flame arrester element (4) together with rack (6) and stabilisation bar (3, 5) for cleaning, after disassembling screws (7, 12, 18) and tubes (10).

Petroleum ether is often a applicable cleaning agent, although the instructions of the corresponding safety data sheet in accordance with directive 91/155/EC need to be observed.

Assembly

After cleaning, reassemble in reverse order.

Tightening moment for screw M16 (7, 18)	: 100 ± 2 Nm
Tightening moment for nut M8 (14, 15)	: 20 ± 2 Nm



Note!

- The stabilisation bar (5) has to be in line with the rack (6) to ensure lowest pressure loss!
- Pay attention for the right gap width of the flame arrester element!
The gap width (**050**) is mentioned on the type label and the flame arrester element (4).
- For safety reason it is not permitted to increase the gaps in the flame arrester elements (e.g. to drill)!
- Check end of line deflagration flame arrester and connections for leak tightness after assembly!

After a deflagration:

- All parts (inside and outside) has to be examined and if necessary exchanged.
- Only use original spare parts of company Flammer!

8. Spare parts

For ordering spare parts please declare:

- Type of product
- Complete serial number
- Spare part no. (Please refer to **fig. 1** for items)

Item	Product	Spare part no.	Remark
4	Flame arrester element	1000-0027-XY	Δ 0.50 mm
5	Stabilization bar	3013-0014-02	
6	Rack	3012-0008-00	
9	Rain cover	3017-0011-00	
14	Nut	9003-0004-00	DIN980 Metallic self-locking
15	Screw	9006-0005-25	EN4017(DIN933) M8 X 25

9. Technical Consultations

Flammer GmbH
Daimlerstr. 3
D-74389 Cleebronn

Tel. : ++49 / (0) 7135 / 93 84 21 0
 Fax. : ++49 / (0) 7135 / 93 84 21 99
 E-mail : info@flammergmbh.de
 Homepage : www.flammergmbh.com

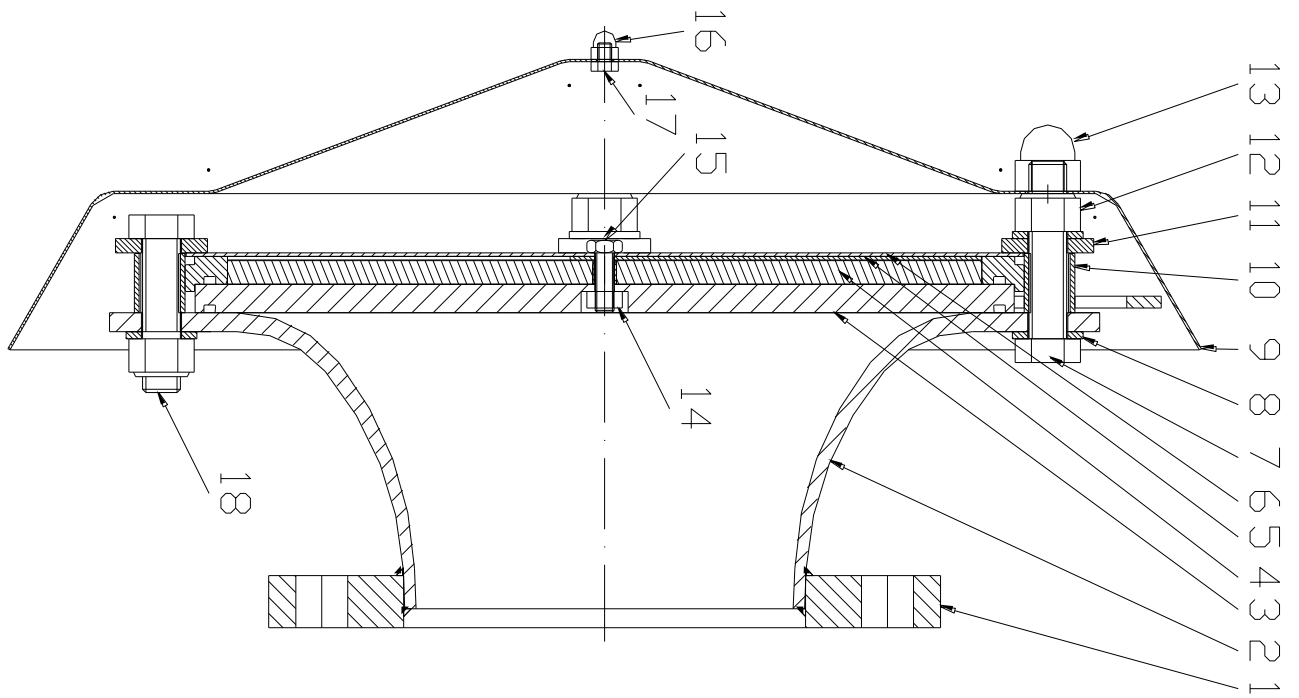

Fig. 1
Construction

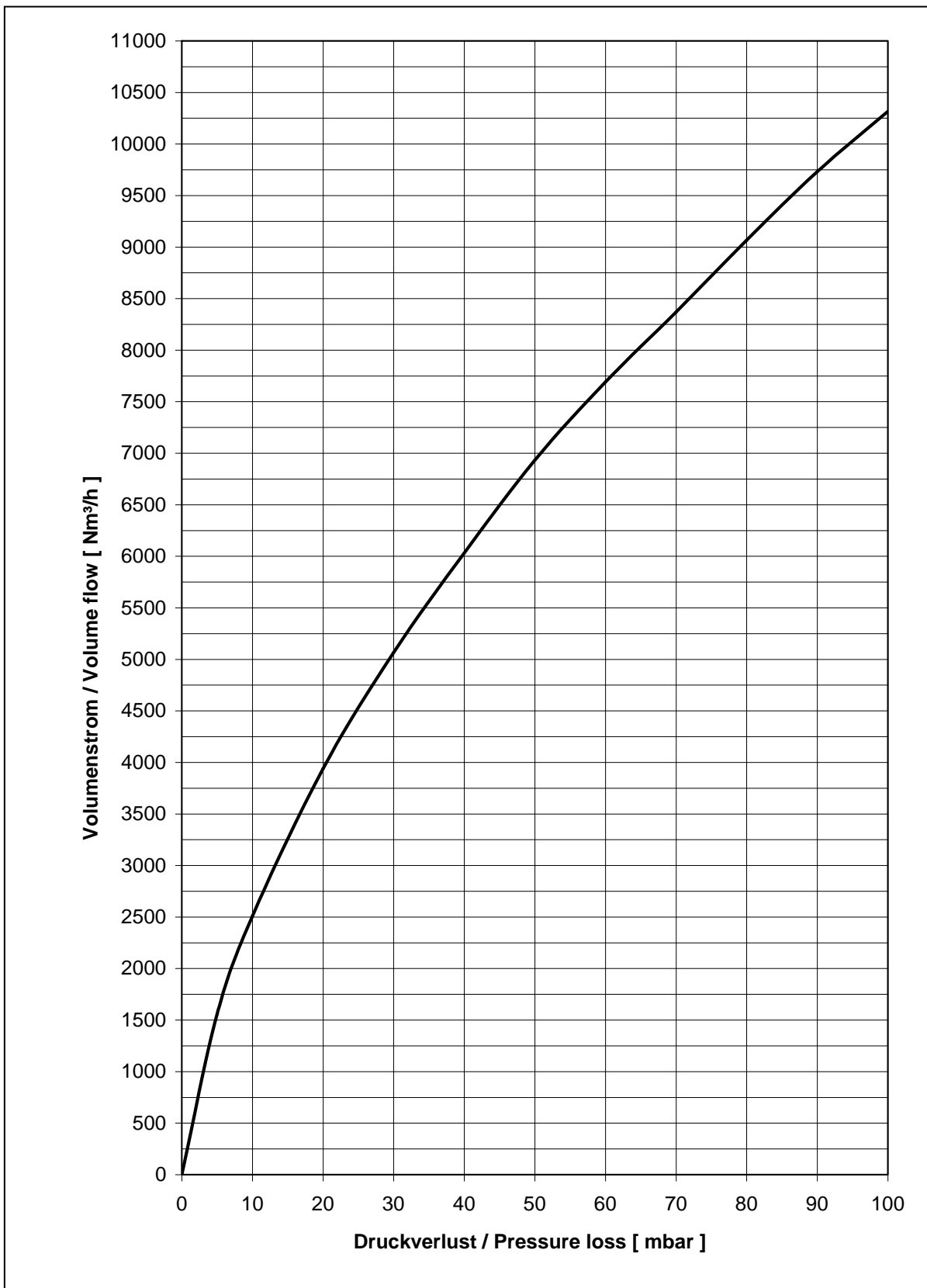

Fig. 2

Pressure loss

Medium : Air at $p_0 = 1013$ mbar, $T_0 = 273K$, density = $1,293$ kg/m³