

Operating Instruction
End of Line Flame Arrester 1018-0001
(Suitable for endurance burning)

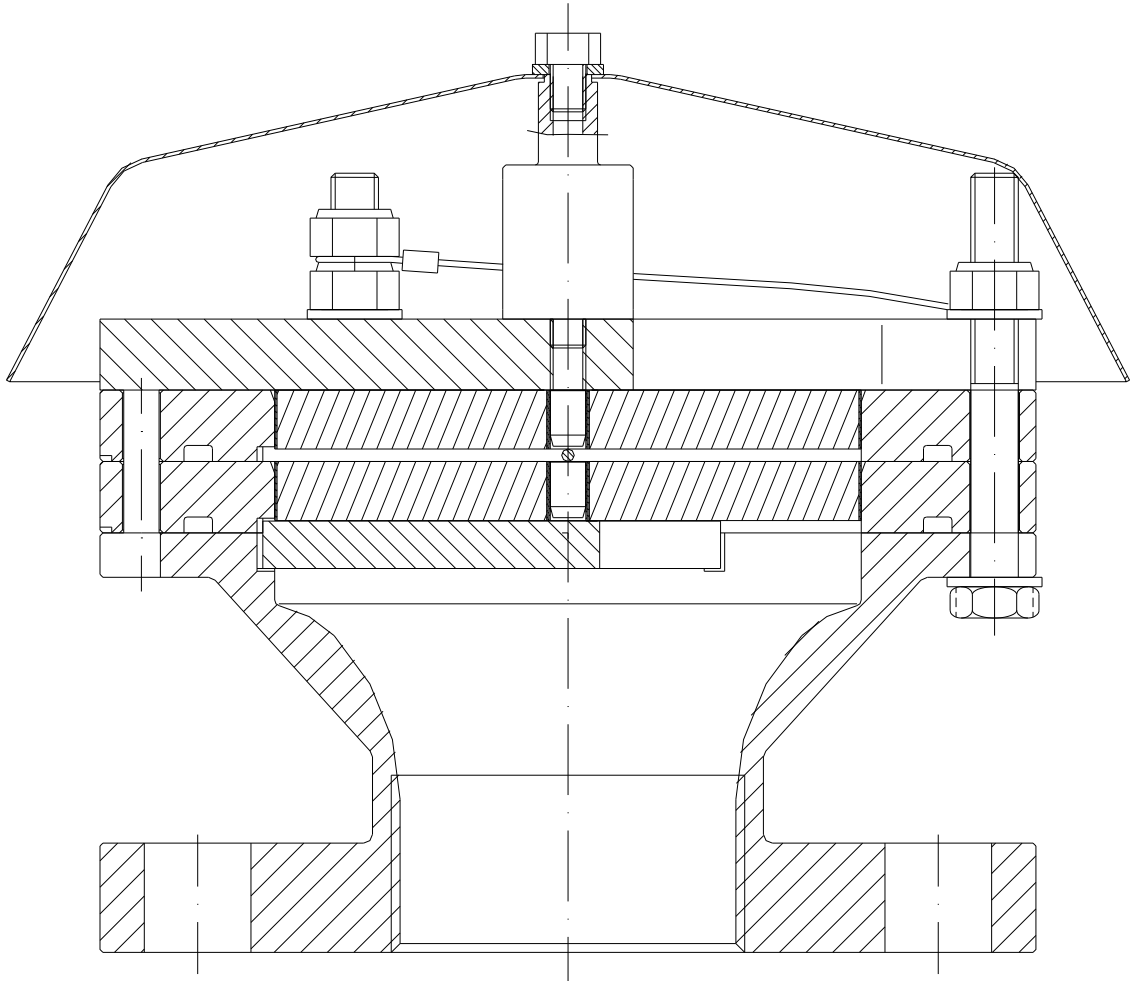

IBExU 09 ATEX 2159 X

 G IIA

 ⁰¹⁰²

1. Preface

This operating instruction apply to end of line 1018–0001, provided the fact that your protective system meet all technical standards described in this document.

End of Line Flame Arrester 1018-0001 is approved for endurance burning of pure hydrocarbon chemicals.

Any information required for the assembly, use and maintenance of the protective system may be obtained from these instructions.

Please read the operating instructions on hand carefully to ensure the safe use of this protective system.

All assembly and maintenance work needs to be carried out by qualified staff. Information provided in this document may be subject to change without prior notice. This document or individual parts of it may not be multiplied or copied without the written consent of Flammer GmbH, irrespective of its purpose.

© 2022 by Flammer GmbH. All rights reserved.

The trade names and/or used name designations, trademarks, etc. (even if not particularly identified), are subject to trademark protection laws and do not justify the assumption that they may be considered as fair use.

The operating instructions on hand correspond to the current technical state of end of line flame arrester 1018-0001. Content subject to change, errors excepted.

In case of dispute, the German text shall prevail.

2. Symbols



Pay attention to accompanying documents!
Important instructions for safe usage!

3. Safety regulations and safety instructions

3.1 Safety regulations

The following regulations and guidelines are to be observed for the use of this protective system:

- EC type examination number IBExU 09 ATEX 2159 X
- DIN EN ISO 16852 Flame arresters
- European Directive 2014/34/EU
- Country-specific safety regulations
- Country-specific provisions for the protection of workers and employees

3.2 Safety instructions

The following instructions are to be observed to guarantee workers' protection and occupational safety:

- Safety regulations in compliance with section 3.1
- Compliance with laws and protective provisions in force at point of application.
- Operators and supervising staff are responsible for the fact that these provisions are observed.
- Assembly and maintenance work is to be carried out by qualified staff.

4. Intended application

The end of line flame arrester type 1018-0001 prevents at the end of vent pipes a light-back at deflagration and endurance burning of potentially explosive vapor-air, and or gas-air mixtures of explosive gases group IIA1, IIA (**pure** hydrocarbon chemicals) with a standard gap (MESG) > 0.9 mm from outside (atmospheric conditions) to protected side.(e. g. storage tank).



Warning!

Flame arresters are limited in mounting and use.

Pay attention to the following hints according to EN ISO 16852

Type	DEF		Deflagration flame arrester
Lu/D	n/a		Not applicable
BC	a		Suitable for endurance burning
EX	G IIA		Explosion group
To	60	[°C]	Maximum operating temperature
po	1.10	[bar]	Maximum absolute operating pressure

4.1 Special requirements for safe use

- Maximum nominal pipe size : DN 50
- Combustible gases, i.e. combustible fluids that occur during operation have to be listed in explosives groups IIA1 or IIA with a standard gap (MESG) > 0.90 mm.
- End of line flame arrester 1018-0001 is approved for pure hydrocarbons chemicals. The end of line flame arrester 1018-0001 is **not** approved for chemicals e.g. alcohols, ketones, amine etc.
- The end of line flame arrester is tested and approved for endurance burning.
- Installation in vertical position only!
- The inline deflagration flame arrester may only be used, if the materials resist against the mechanical and/or chemical influences under the actual operating conditions, in such a way, that explosion protection is always guaranteed. This applies particularly to the flame arrester elements whose protection against flame transmission may be endangered by corrosion among others.

5. Technical specifications

(See figure 1)

Connection	: Flange EN1092-1 (DIN 2576) PN10(16)
Connection thread	: G 2" (ISO 228-1) internal
Pressure loss	: see fig. 2

6. Assembly

(See figure 1)

Note!

Do not handle the armature by the rain cover (5) because this could damage the temperature safety element (6) and cause an accidental release.

The end of line deflagration flame arrester is to be fully joined to the respective connecting parts.



- Note requirements of chapter 4.
- Do not handle the armature by the rain cover (5) because this could damage the temperature safety element (6) and cause an accidental release.

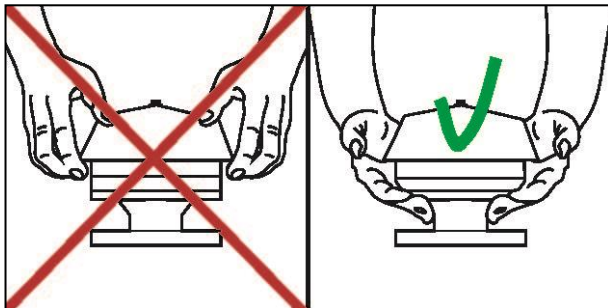

- The internal diameter of the connecting parts may not exceed the maximum permitted nominal pipe size.
- Any connection is to be sufficiently sealed with suitable media resistant sealing and checked for leakage. (Maximum test pressure $p_e = 12$ bar).
- Pay attention to professional earthing!
- Due to possible bimetallic corrosion (contact corrosion), we advise against use galvanized steel fittings in connection with stainless steel installations.

7. Maintenance

(See fig.1)

In order to keep flow resistance at a constantly low level, it is necessary to regularly check the end of line flame arrester for impurities, and clean it, if required.

To do this, unscrew the bolt (8) and take of carefully the rain cover (5).

(Attention: spring power possible)

Disassemble the rack (9) together with flame arrester elements (10) and distance bar (11) after disconnecting the three bolts (2).

Clean the flame arrester elements (10).

Petroleum ether is often a suitable cleaning agent, it is, however, necessary to fulfill all related safety data sheet instructions in accordance with directive 91/155/EC.



- Do not bypass, take away or disassemble the temperature safety element (6).
- While cleaning, do not push on ribbon of flame arrester element (10) in axial direction.
- For safety reason it is not permitted to increase the gaps in the flame arrester elements (e.g. to drill).
- Reassemble end of line flame arrester 1018-0001 in reverse order.
- Take care for the right position of the catching rope (13)

- Tightening moment of screws (2) : **6⁺¹ Nm**
- Tightening moment of screw (8) : **0.50^{+0.50} Nm**

- Only original spare parts from company Flammer GmbH have to be installed.

Exchange of temperature safety element (6)

Disassemble parts of old safety element from bar (9) and rain cover (5).

Assemble new safety element (6) hand tight to bar (9).

Assemble rain cover with screw and washer (7, 8).



Lock thread with intermediate strength adhesive. (e. g. Loctite 243)
Tightening moment of screw (8): **0.50^{+0.50} Nm**

After a deflagration

- All parts (inside and outside) has to be examined and if necessary exchanged.
- In any case, replace the temperature safety element (6).(See above)

After endurance burning

- End of line flame arrester has to be sent back for general repairing.

8. Spare parts

For ordering spare parts we need following information:

- Complete serial number (SN)
- Order number of the spare parts
- Type number of the product

Please refer to **fig. 1** for items.

Item	Product	Order number
5	Rain cover	3017-0007-00
6	Temperature safety element	2002-0001-00
13	Catching rope	3013-0005-00

9. Technical Consulting

Flammer GmbH
Daimlerstraße 3
D-74389 Cleebronn

Tel. : ++49 / (0) 7135 / 93 84 21 0
Fax. : ++49 / (0) 7135 / 93 84 21 99
e-mail : info@flammergmbh.de
Homepage : www.flammergmbh.de

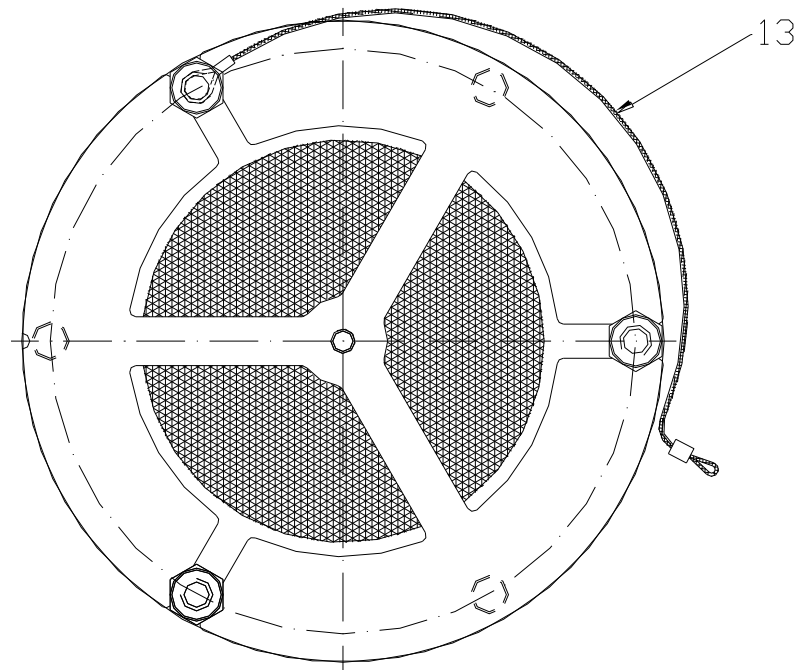
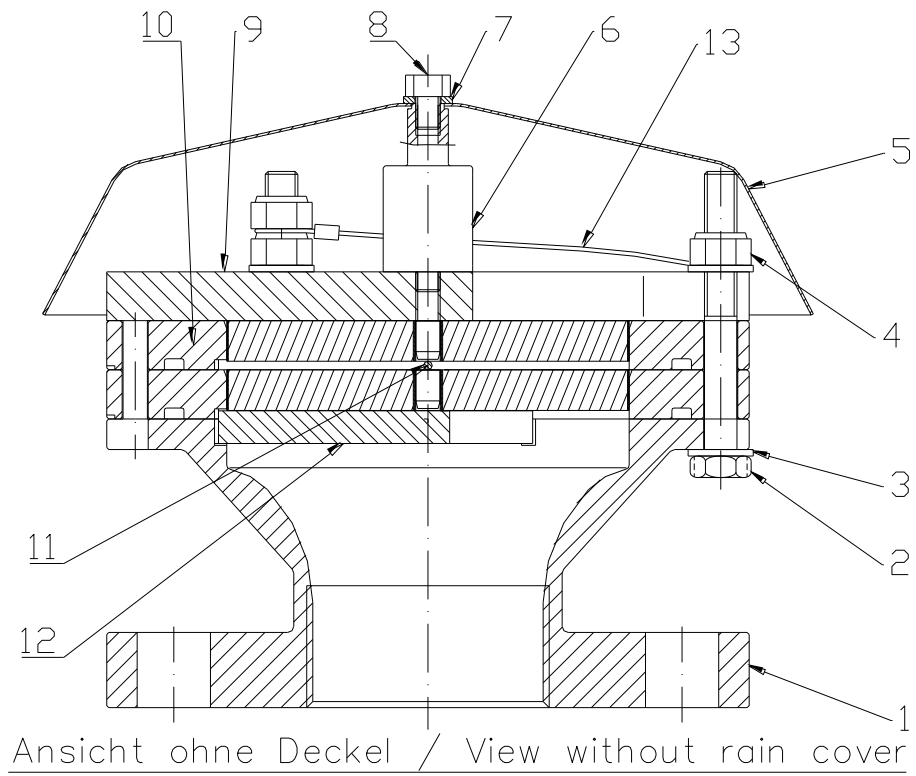

Fig. 1
Construction

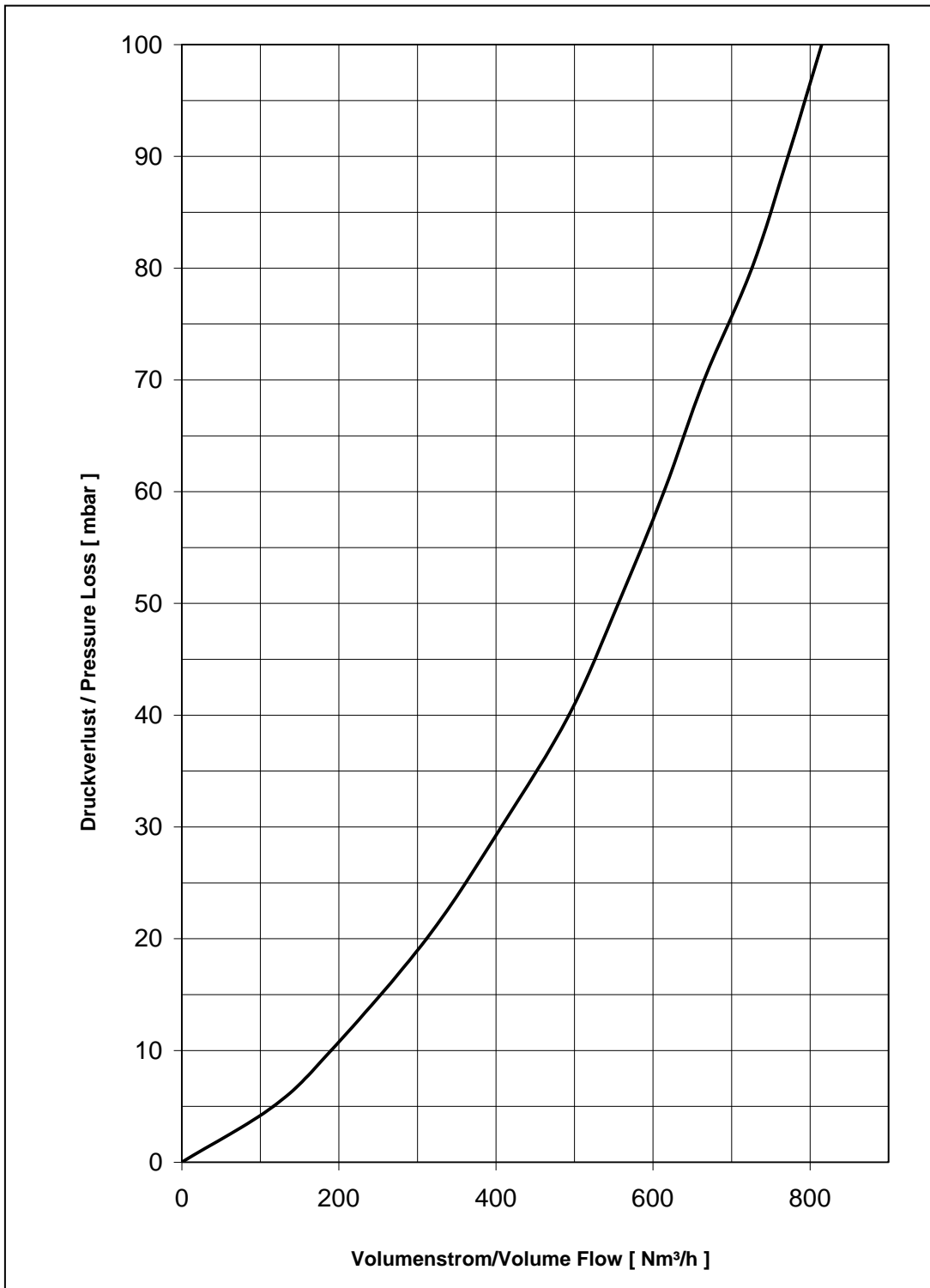

Fig.2

Pressure loss

Medium : Air at $p_0 = 1013 \text{ mbar}$, $T_0 = 273\text{K}$, density = $1,293 \text{ kg/m}^3$