

Operating Instruction
Inline Deflagration Flame Arrester 1023-0001
(Suitable for short time burning)

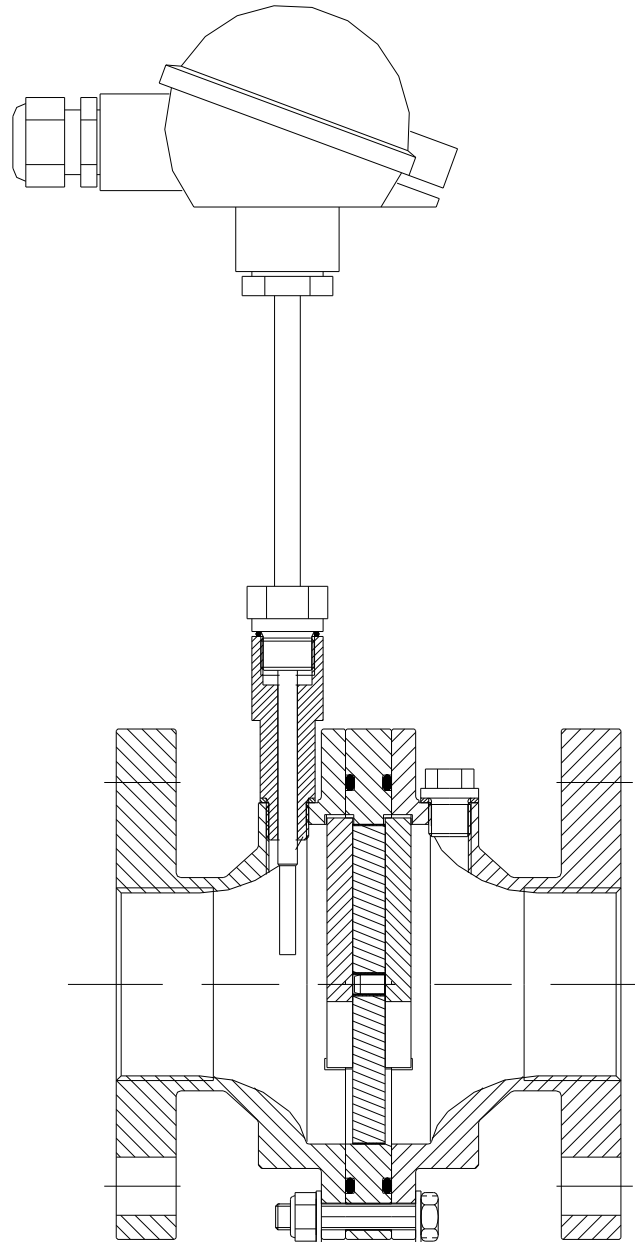

IBExU 09 ATEX 2019 X

 G IIA

 ⁰¹⁰²

1. Preface

This operating instruction apply to inline deflagration flame arrester 1023-0001, provided the fact that your in-line deflagration flame arrester meets all technical standards described in this document.

Any information required for the assembly, use and maintenance of the protective system may be obtained from these instructions.

Please read the operating instructions on hand carefully to ensure the safe use of this in-line deflagration flame arrester.

All assembly and maintenance work needs to be carried out by qualified staff.

Information provided in this document may be subject to change without prior notice.

This document or individual parts of it may not be multiplied or copied without the written consent of Flammer GmbH, irrespective of its purpose.

© 2022 by Flammer GmbH. All rights reserved.

The trade and/or used name designations, trademarks, etc., even when not specially marked, do not justify the assumption that they may be considered as fair use, as defined by trademark protection laws. Changes and errors excepted.

In case of dispute, the German text shall prevail.

2. Symbols



Take note of the accompanying documents!
Important instructions for safe usage

3. Safety regulations and safety instructions

3.1 Safety regulations

The following regulations and guidelines are to be observed for the use of this protective system:

- EC type examination number IBExU 09 ATEX 2019 X
- DIN EN ISO 16852 Flame arresters
- European Directive 2014/34/EU
- National safety regulations
- National workers' protection regulations

3.2 Safety instructions

The following instructions are to be observed to guarantee workers protection and occupational safety:

- Safety regulations in compliance with section 3.1
- Observation of laws and provisions in force at the place of application.
- Operators and supervising staff are responsible for the fact that these provisions are observed.
- Assembly and maintenance work is to be carried out by qualified staff.

4. Purpose of use

The inline deflagration flame arrester type 1023-0001 prevents light-back at deflagration of potentially explosive vapour-air, and or gas-air mixtures of explosives group IIA1, IIA with a standard gap (MESG) > 0.9 mm at an absolute working pressure of $p_{abs} \leq 1.20$ bar in an ignition source preceding pipe with a maximum nominal diameter of DN = 50 mm and a corresponding maximum length of L = 2500 mm.

For detection of a stabilized flame a PT100 temperature sensor mounted on the unprotected side as described in chapter 6 is necessary!

When a stabilized flame is detected an action within 30 seconds has to be carried out which ensures a safe quenching of the flame. (E.g. stopping the gas flow)



Warning!

Flame arresters are limited in mounting and use.

Pay attention to the following hints according to EN ISO 16852

Type	DEF		Deflagration flame arrester
Lu/D	50		Explanation see chapter 4.1
BC	b		Suitable for short time burning
EX	G IIA		Explosion group
To	60	[°C]	Maximum operating temperature
po	1.20	[bar]	Maximum absolute operating pressure

4.1 Special requirements for safe usage

- Max. nominal pipe diameter DN between the possible ignition source and the deflagration flame arrester : DN50
- Max. pipe length L (incl. connecting parts) between the possible ignition source and the in-line deflagration flame arrester. : $50 \cdot DN$
Example: The allowed maximum pipe length is $L = 50 \cdot DN = 2500$ mm for a connected nominal pipe diameter of $DN = 50$ mm
- The nominal pipe diameter on the unprotected side shall be no larger than the flame arrester connection. The nominal pipe diameter on the protected side shall be no less than the pipe diameter on the unprotected side.
- The Inline deflagration flame arrester may only be used, if the materials resist against the mechanical and/or chemical influences under the actual operating conditions, in such a way, that explosion protection is always guaranteed. This applies particularly to the flame arrester elements whose protection against flame transmission may be endangered by corrosion among others.
- Pipe branches and valves on the unprotected side shall be installed as close as possible to the in-line deflagration flame arrester.
- Shut off valves before and after the flame arrester has to be fully open during normal operation.
- The inline deflagration flame arrester is bi-directional, i.e. that it may be connected to either side of the system and may be fitted in any position.
- Combustible gases and or liquids produced during operation must pertain to explosives group IIA1 or IIA with a standard gap (MESG) > 0.90 mm.
- The in-line deflagration flame arrester is **tested and authorised for short time burning**. For detection of a stabilized flame a PT100 temperature sensor mounted on the unprotected side is necessary. When a flame is detected an action within 30 seconds has to be carried out which ensures a safe quenching of the flame. (E.g. stopping the gas flow)
- The inline deflagration flame arrester is **not tested and authorised for endurance burning!**

5. Technical specifications

(See figure 1)

Connection : Flange EN1092-1 (DIN 2576) PN10(16)
 Connecting thread : G2" ISO 228-1 internal
 Pressure loss : see fig. 2

6. Assembly

(See figure 1)

The inline deflagration flame arrester is to be fully and stressless joined to the respective connecting parts.



- Note requirements of chapter 4.
- The internal diameter of the connecting parts may not exceed the maximum permitted nominal pipe size.
- Any connection is to be sufficiently sealed with suitable media resistant sealing and checked for leakage. (Maximum test pressure $p_e = 12$ bar).
- Pay attention to professional earthing!
- Due to possible bimetallic corrosion (contact corrosion), we advise against use galvanized steel fittings in connection with stainless steel installations.

Temperature sensor

- For mounting temperature sensor (16) first remove lock screw (10) and assemble sensor together with a new media resistant gasket and ensure electrical connection with corresponding monitoring device.
- The **release temperature** of the monitoring device should 30 K above the maximum operating temperature.
- The temperature sensor has to be mounted only together with adaptor (11).
- The temperature sensor (12) has to fulfil the below specification.

	Description
Supplier	Temperaturmeßtechnik Geraberg GmbH
Order number	VH 55.0i201-1014782
Model	PT100
Circuit type	4-wire
Thread connection	G 3/8"

- For assembly and usage of temperature sensor refer to appropriate operating manual.
- The temperature sensor has to be mounted on the unprotected side.
- Usage of other temperature sensor type has to be approved by Flammer GmbH.

7. Maintenance

To keep flow resistance at a constantly low level, the inline deflagration flame arrester is to be checked for impurities and, if necessary cleaned, in regular intervals.

Disassembling

Unscrew the bolts (2, 3) then remove a housing (1) and the flame arrester element (5).

If O-ring (6) is damaged change it.

Petroleum ether is often a suitable cleaning agent, although the instructions of the corresponding safety data sheet in accordance with directive 91/155/EC need to be observed.

Assembly

After cleaning, reassemble in reverse order.

Look out for the accurate position of the stabilisation rack (9) to ensure a low pressure loss and a proper stabilisation of the flame arrester element.

For this the stabilisation racks (9) should be in line.

The position of the stabilisation rack is marked outside of the flame arrester element and the housing by a groove. After assembly the following picture should be visible. In this case all parts are in the right position.

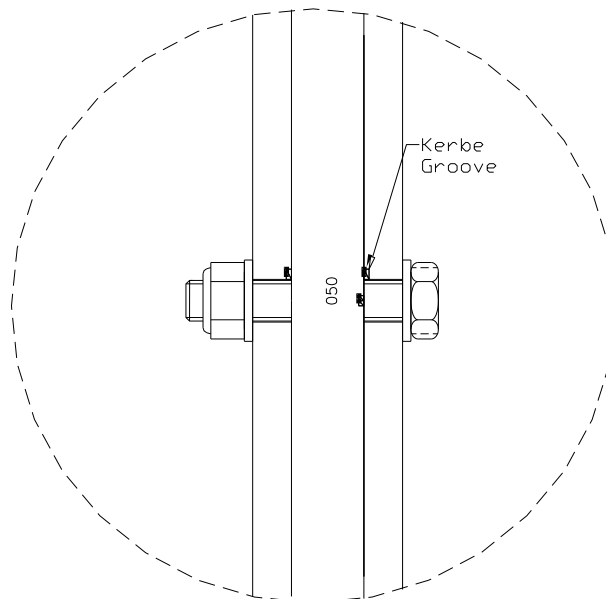

Tightening moment of nut M8 (2, 3) : 20 ± 2 Nm



Note!

- Pay attention for the right gap width of the flame arrester element.
The gap width (Δ **0,50 mm**) is mentioned on the type label and every flame arrester element.(see fig. above)
- For safety reason it is not permitted to increase the gaps in the flame arrester elements (e.g. to drill).
- After assembly in line deflagration flame arrester and connections have to be tested for leak tightness. (Maximum test pressure $p_e = 12$ bar).
- Tighten screws with the required tightening moment after 15 minutes again when using PTFE O-rings.

After a deflagration or a short time burning:

- All parts (inside and outside) has to be examined and if necessary exchanged.
- In any case, flame arrester element (5) should be replaced.

8. Spare parts

For ordering spare parts please declare:

- Type of product
- Complete serial number
- Spare part no. (Please refer to **fig. 1** for items)

Item	Product	Spare part no.
5, 6	Spare part set	8001-0020
6	FPM O-Ring	9013-0001-00
6	PTFE O-Ring	9013-0011-00
11	Adaptor	3007-0022-XX
12	Temperature sensor	9026-0002-00

9. Technical Consultations

Flammer GmbH
Daimlerstraße 3
D-74389 Cleebronn

Tel. : ++49 / (0) 7135 / 93 84 21 0
Fax. : ++49 / (0) 7135 / 93 84 21 99
e-mail : info@flammergmbh.de
Homepage : www.flammergmbh.com

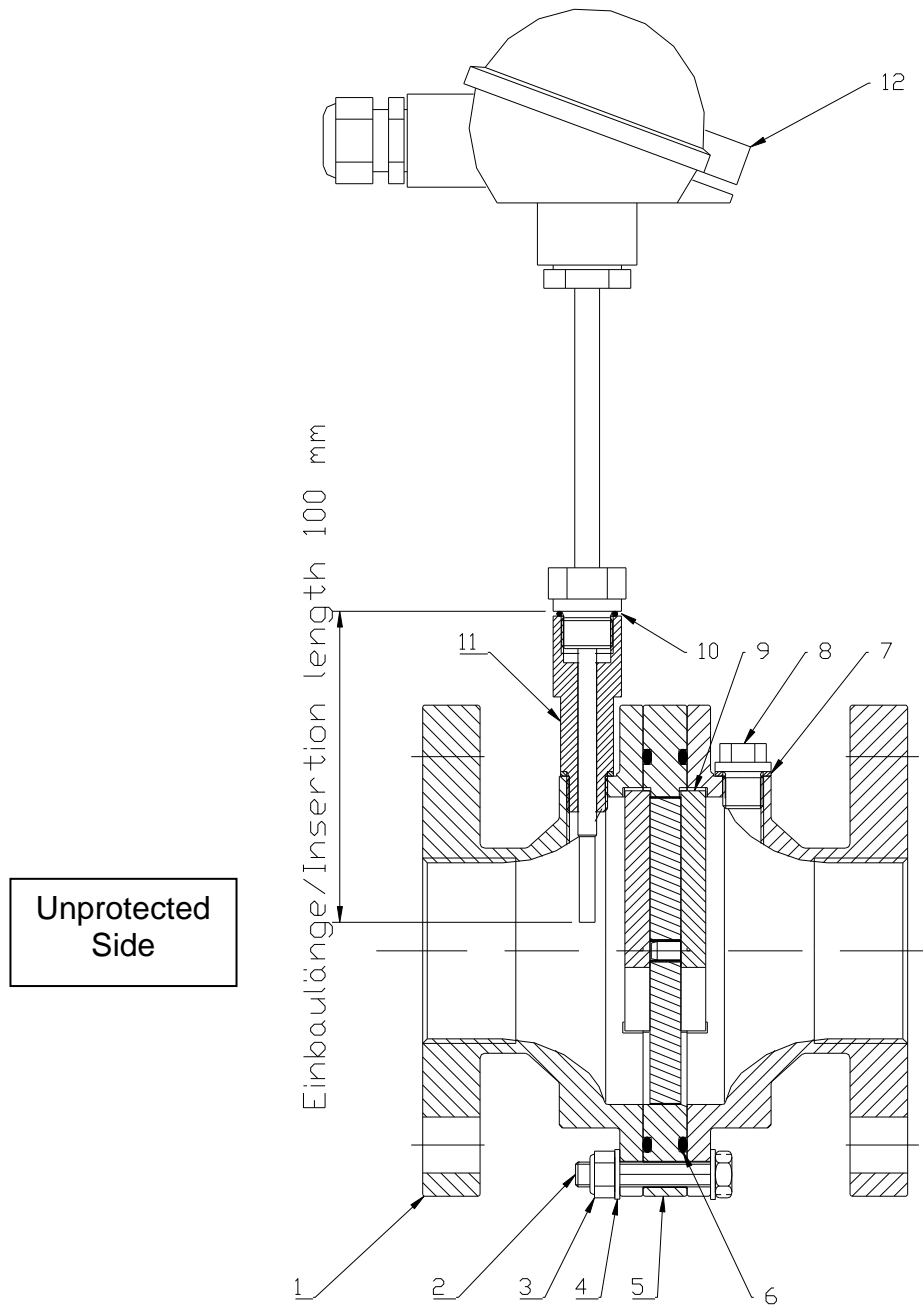

Fig. 1
Construction

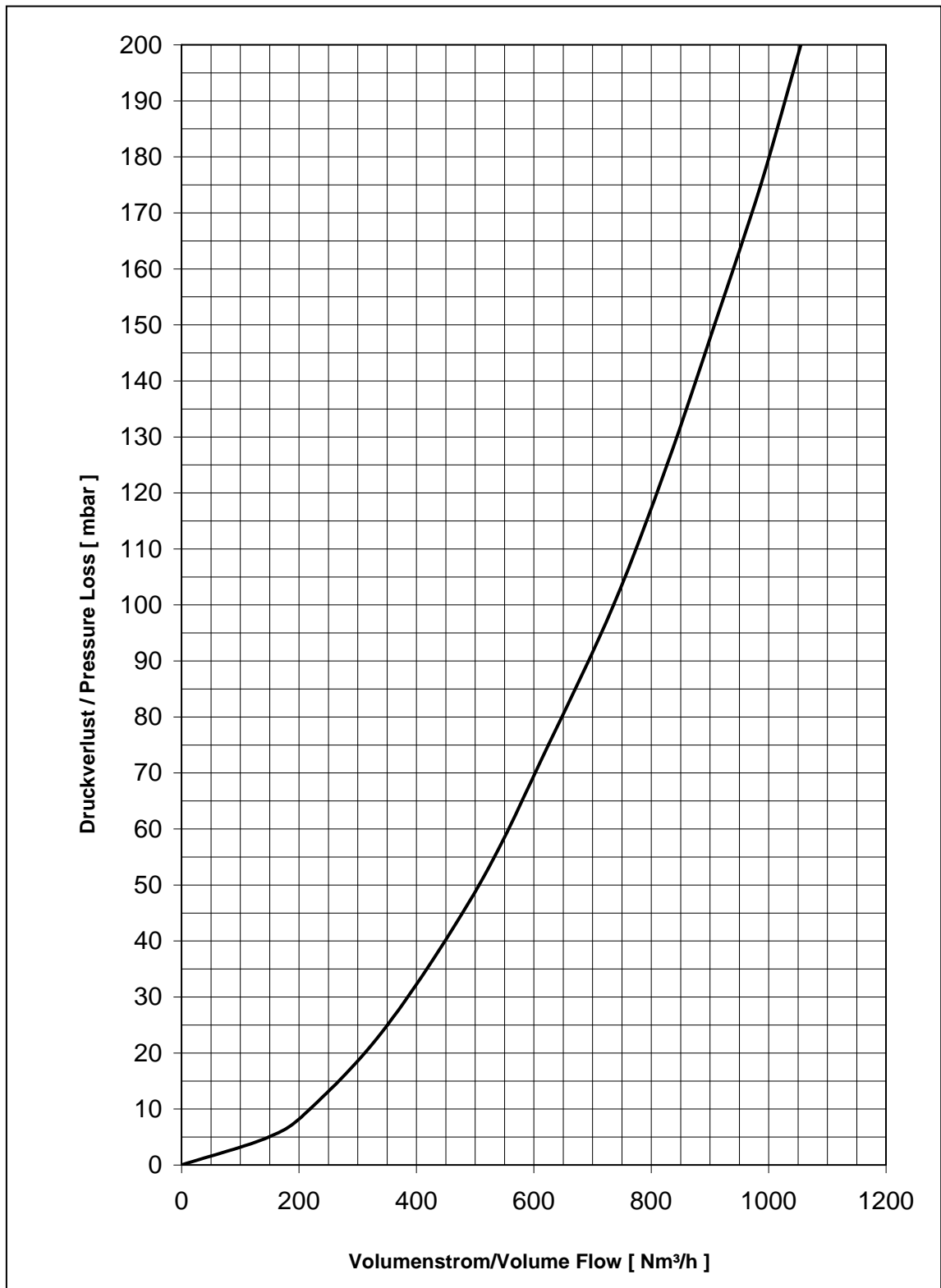

Fig. 2

Pressure loss

Medium : Air at $p_0 = 1013 \text{ mbar}$, $T_0 = 273\text{K}$, density = $1,293 \text{ kg/m}^3$